

FELLA

Futterernte-Technik

Turboschwader

Bedienungsanleitung + Ersatzteilliste
Instructions de Service et Liste des Pièces de Rechange
Operating Instructions and Spare Parts List
Istruzioni sull'uso e distina delle parti di ricambio
Gebruiksaanwijzing en Onderdeelenlist
Bruksanvisning och Reservdelslista

TS 295 RDF

TS 335 RDF

ab Masch.-Nr. 0976

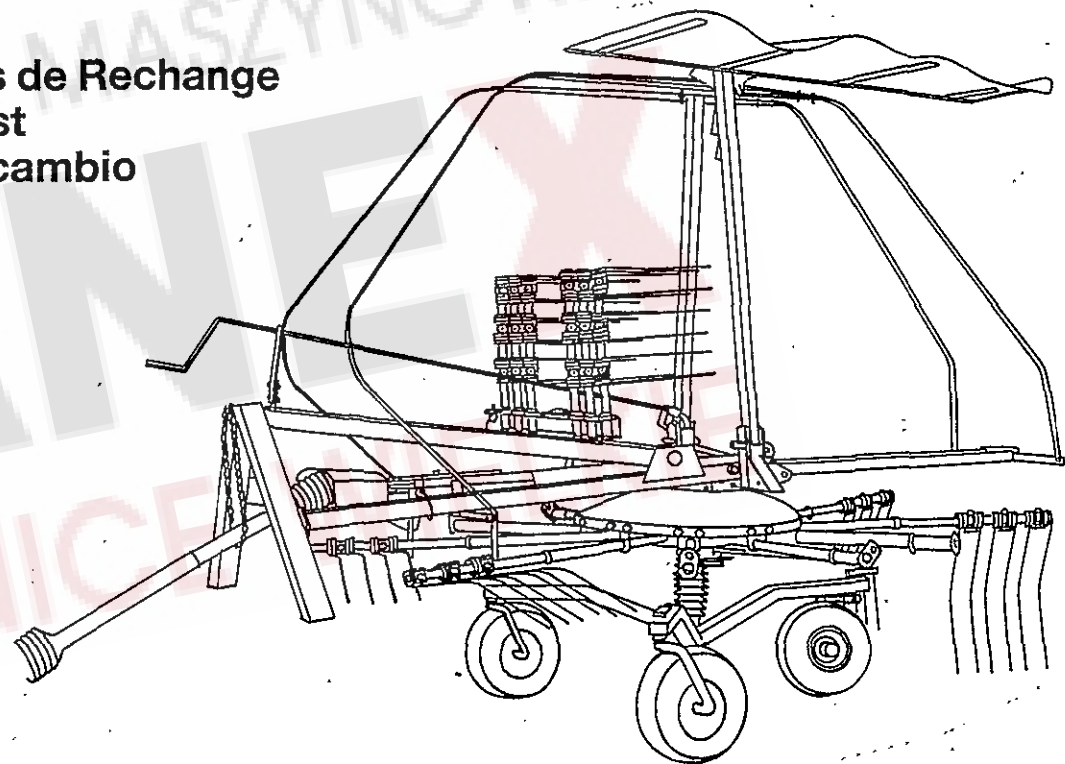

Ausgabe · Edition · Edition · Edizione · Uitgave · Utgava

01.90

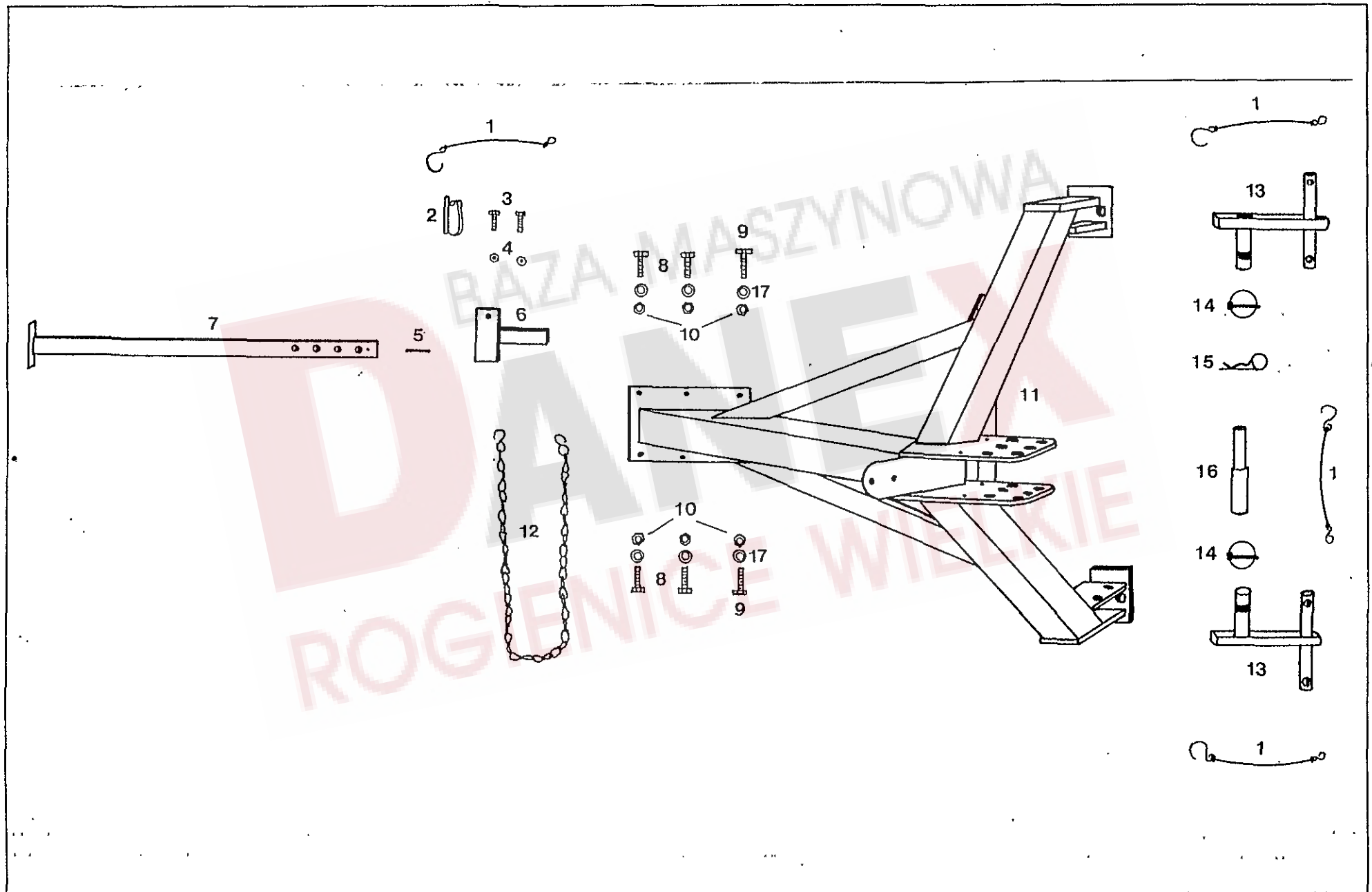

Pos.Nr.	Bezeichnung des Teiles	X = Verschleißteil	* = kein Ersatzteil	Nr.			
Pos.no.	Description of the part.	X = weare part	* = no spare part	No.			
Rep.	Désignation de la pièce	X = pièces d'usure	* = no pièce de rechange	No.			
Pos.no.	Descrizione del pezzo			No.			
	Dreipunktbock starr, Stütze, Kurbel		3-point headrack inflexible, support, crank				Attelage 3-point raide, support, manivelle
1	Sicherungsschnur		Safety cord	111 895	X		
2	Federsteckbolzen 12x55 ABK-F verz.		Clip-on bolt	106 857	X		
3	6kt.-Schraube M 12x30 DIN 933-8.8 A3A		Hexagonal bolt	116 628	●		
4	Sicherungsmutter M 12 DIN 6925-8 A3A		Retaining nut	108 589	●		
5	Spannhülse 6x45 DIN 1481 ZN 3		Clamping sleeve	107 453	●		
6	Halter		Support	492 393G	●		
7	Stütze		Support	492 312G	●		
8	6kt.-Schraube M 12x40 DIN 933-10.9 A3A, verb.-plus		Hexagonal bolt	126 383	●		
9	6kt.-Schraube M 12x45 DIN 933-10.9 A3A, verb.-plus		Hexagonal bolt	126 585	●		
10	Sicherungsmutter M 12 DIN 6925-10 A3A		Retaining nut	124 710	●		
11	Dreipunktbock		3-point headrack	492 267G	●		
12	Knotenkette Ø2,8 DIN5686 22 Glieder, ca.940mm verz.		Link chain	117 245	X		
13	Unterlenkerlasche		Lower link tongue	492 385G	●		
14	Klappstecker 12 DIN 11023		Folding plug	108 544	X		
15	Federstecker 5 DIN 11024 ZN 3		Plug	115 916	X		
16	Oberlenkerstufenbolzen		Bolt of upper link assembly	122 613	●		
17	Scheibe 13 DIN 125 ZN 3		Washer	105 186	●		

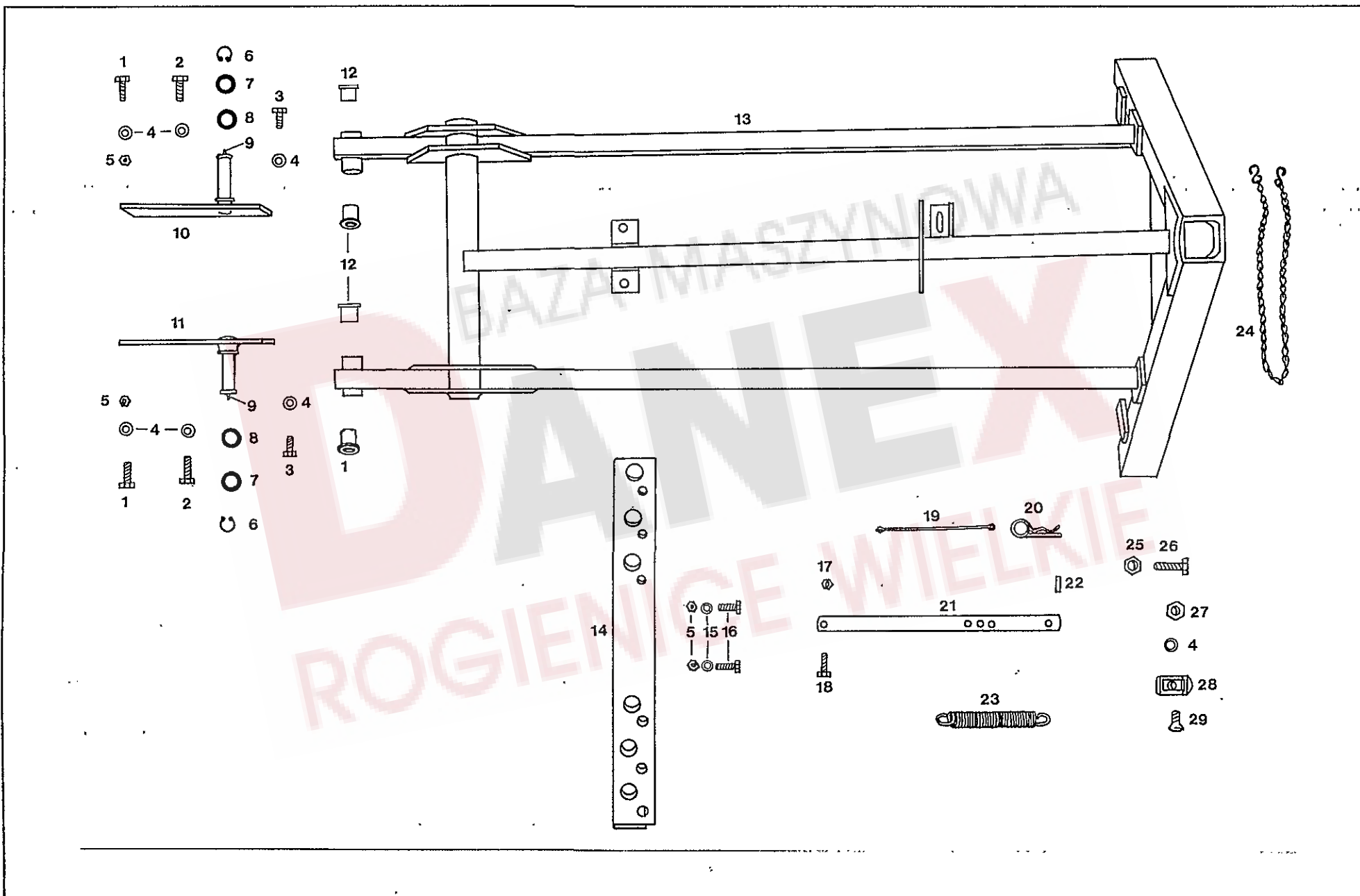

Pos.Nr. Pos.no. Rep. Pos. no.	Bezeichnung des Teiles Description of the part. Désignation de la pièce Descrizione del pezzo	X = Verschleißteil X = weare part X = pièces d'usure	* = kein Ersatzteil * = no spare part * = no pièce de rechange	Nr. No. No. No.	TS339RDF			
	Anbaubock							
1	6kt.-Schraube M 12x45 DIN 931-8.8 A3A			126 771	●			
2	6kt.-Schraube M 12x40 DIN 933-10.9 A3A verbus-plus			126 383	●			
3	6kt.-Schraube M 12x30 DIN 933-10.9 A3A verbus-plus			126 308	●			
4	Scheibe 13 DIN 125 St ZN 3			105 186	●			
5	Sicherungsmutter M 12 DIN 6925-10 A3A			124 710	●			
6	Sicherungsring 28x2 DIN 471			118 973	●			
7	Scheibe			224 473	●			
8	Paßscheibe 28x40x2 DIN 988			126 929	●			
9	Kegelschmiernippel AS 6 DIN 71412			108 294	●			
10	Scharnierstück, links			497 175	●			
11	Scharnierstück, rechts			497 174	●			
12	Buchse			121 024	●			
13	Anbaubock			497 067	●			
14	Träger			497 008	●			
15	Scheibe			464 006	●			
16	6kt.-Schraube M 12x40 DIN 933-8.8 A3A			116 630	●			
17	Sicherungsmutter M 10 DIN 6925-8 A3A			108 441	●			
18	6kt.-Schraube M 10x30 DIN 933-8.8 A3A			107 735	●			
19	Sicherungsschnur			122 466	X			
20	Federstecker 5 DIN 11024 ZN 3			115 916	X			
21	Stütze			497 072	●			
22	Spannstift 8x30 DIN 1481			108 745	●			
23	Zugfeder			122 473	●			
24	Knotenkette 22 Glieder Ø 2,8 DIN 5686			117 245	X			
25	6kt.-Mutter M 12 DIN 934-A3A			116 686	●			
26	6kt.-Schraube M 12x60 DIN 933-8.8 A3A			117 726	●			
27	6kt.-Mutter M 12 DIN 936-8 A3A			118 097	●			
28	Schieber			121 735	●			
29	Senkschraube M 12x25 DIN 7991-8.8 A3A			124 980	●			
	Headrack							
	Hexagonal bolt							
	Hexagonal bolt							
	Hexagonal bolt							
	Washer							
	Retaining nut							
	Snap ring							
	Washer							
	Fitting plate							
	Conical grease nipple							
	Hinge piece left							
	Hinge piece right							
	Bush							
	Headrack							
	Carrier							
	Washer							
	Hexagonal bolt							
	Retaining nut							
	Hexagonal bolt							
	Safety cord							
	Plug							
	Support							
	Tension pin							
	Pulling spring							
	Link chain							
	Hexagonal nut							
	Hexagonal bolt							
	Hexagonal nut							
	Slider							
	Countersunk screw							
	Attelage							
	Vis à 6 pans							
	Vis à 6 pans							
	Vis à 6 pans							
	Rondelle							
	Ecrou de maintien							
	Circlip extérieur							
	Rondelle							
	Rondelle de fixation							
	Graisseur conique							
	Pièce de charnière gauche							
	Pièce charnière droit							
	Douille							
	Attelage							
	Bras portant							
	Rondelle							
	Vis à 6 pans							
	Ecrou de maintien							
	Vis à 6 pans							
	Cordon d'arrêt							
	Fiche							
	Support							
	Goupille							
	Ressort de tension							
	Chaîne à joints							
	Ecrou à 6 pans							
	Vis à 6 pans							
	Ecrou à 6 pans							
	Coulisse							
	Vis noyée							

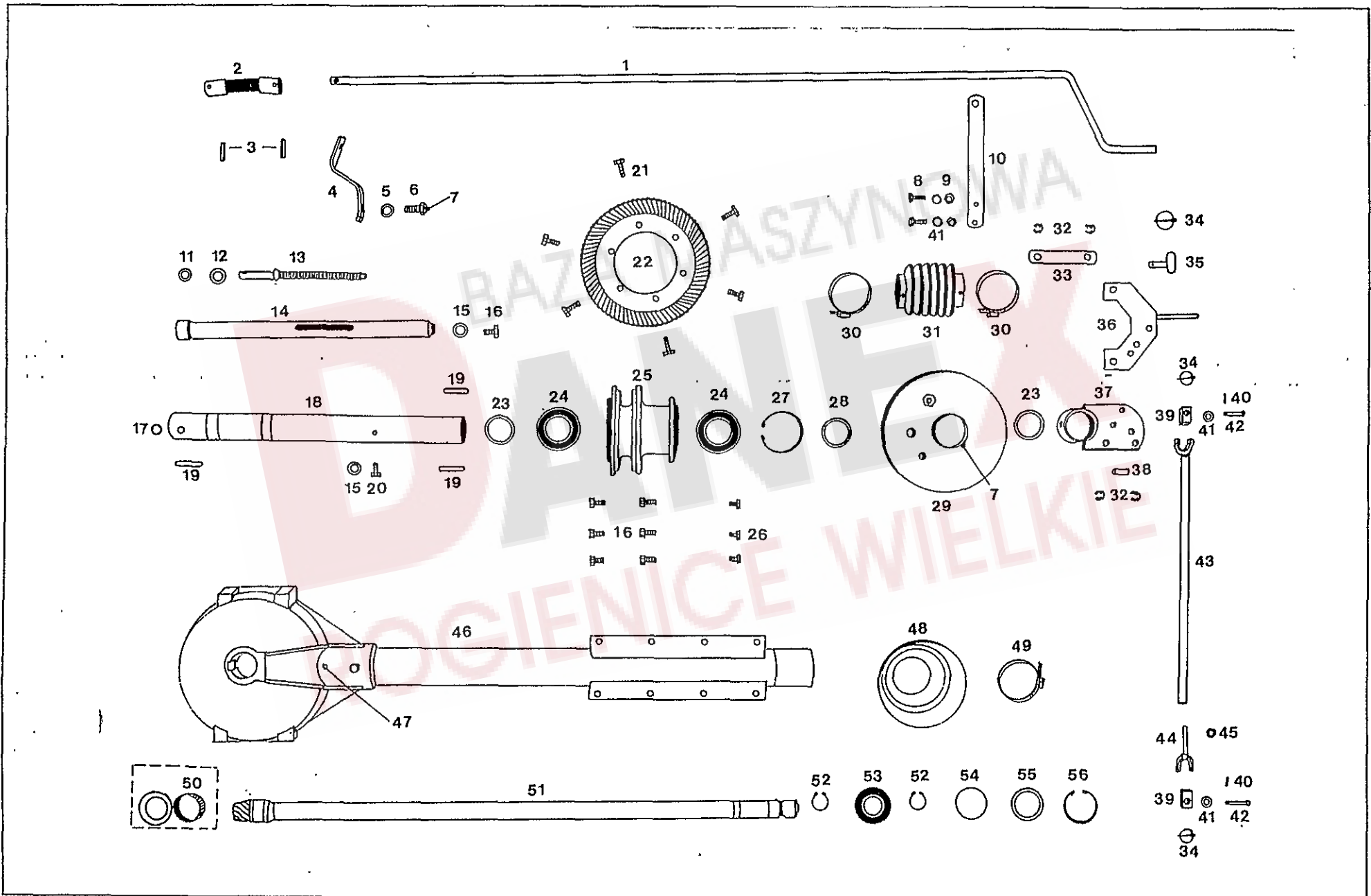

Pos.Nr.	Bezeichnung des Teiles	X = Verschleißteil	* = kein Ersatzteil	Nr.	TS295RDF	TS335RDF
Pos.no.	Description of the part.	X = weare part	* = no spare part	No.		
Rep.	Désignation de la pièce	X = pièces d'usure	* = no pièce de rechange	No.		
Pos. no.	Descrizione del pezzo			No.		
	Rahmen, Getriebewelle und Steuerungseinrichtung					
	Frame, gear shaft and steering mechanism					
	Châssis, Arbre de transmission de distribution					
1	Kurbel				*	*
2	Biegsame Welle			121 970	•	•
3	Spannstift 8x36 DIN 1481 ZN 3			107 464	•	•
4	Kurbelhalter			492 359	•	•
5	Scheibe 17 DIN 125 ZN 3			115 979	•	•
6	6kt.-Schraube M 16x40			492 361	•	•
7	Schmiernippel AS 8x1x3,5 DIN 71412			124 608	•	•
8	6kt.-Schraube M 10x35 DIN 933-8.8 A3A			116 623	•	•
9	Sicherungsmutter M 10 DIN 6925-8 A3A			108 441	•	•
10	Kurbelhalter, vorn				*	*
11	Scheibe 19 DIN 1441			116 024	•	•
12	Axial-Rillenkugellager 51104 DIN 711			124 131	•	•
13	Spindel			492 886G	•	•
14	Hubstange			492 879	•	•
15	Scheibe 13 DIN 125 ZN 3			105 186	•	•
16	6kt.-Schraube M 12x30 DIN 933-10.9 A3A			126 308	•	•
17	Runddichtring 17x3,5 DIN 3770 NB 70			126 417	•	•
18	Kreiselachse			492 876G	•	•
19	Paßfeder A 12x8x56 DIN 6885 C45K+V			108 319	•	•
20	Zylinderschraube			122 079	•	•
21	Zylinderschraube M12x30 DIN7984-8.8 A3A Verbus-plus			126 303	•	•
22	Tellerrad			121 914	•	•
23	Paßscheibe 60x75x0,3 DIN 988 (n. Bedarf)			126 384	•	•
23	Paßscheibe 60x75x0,5 DIN 988 (n. Bedarf)			126 385	•	•
23	Paßscheibe 60x75x0,1 DIN 988 (n. Bedarf)			124 650	•	•
24	Rillenkugellager 6012-2 RS DIN 625			118 604	•	•
25	Nabe			492 255	•	•
26	6kt.-Schraube M 12x20 DIN 933-8.8 A3A Verbus-plus			124 331	•	•
27	Sicherungsring 95x3 DIN 472			116 043	•	•
28	Stützscheibe 60x75x3 DIN 988			126 302	•	•
29	Kurvenscheibe			492 934G	•	•
30	Schlauchschele SA 70x90 SKZ DIN 3017			117 831	•	•
31	Faltenbalg			121 990	•	•
32	KL-Sicherung 16 SXN09			124 826	•	•
33	Schaltflasche			492 420	•	•
34	Klappstecker 5 DIN 11023 ZN 3			109 162	X	X
35	Stecker			492 419G	•	•
36	Steuerhebel			492 366G	•	•
36	Steuerhebel			492 367	•	•
37	Buchse			492 318G	•	•
38	Scharnierbolzen			121 993	•	•
39	Gelenk			492 288	•	•
	Fortsetzung nächste Seite					
	Continued on next page					
	Continué sur la page suivante					

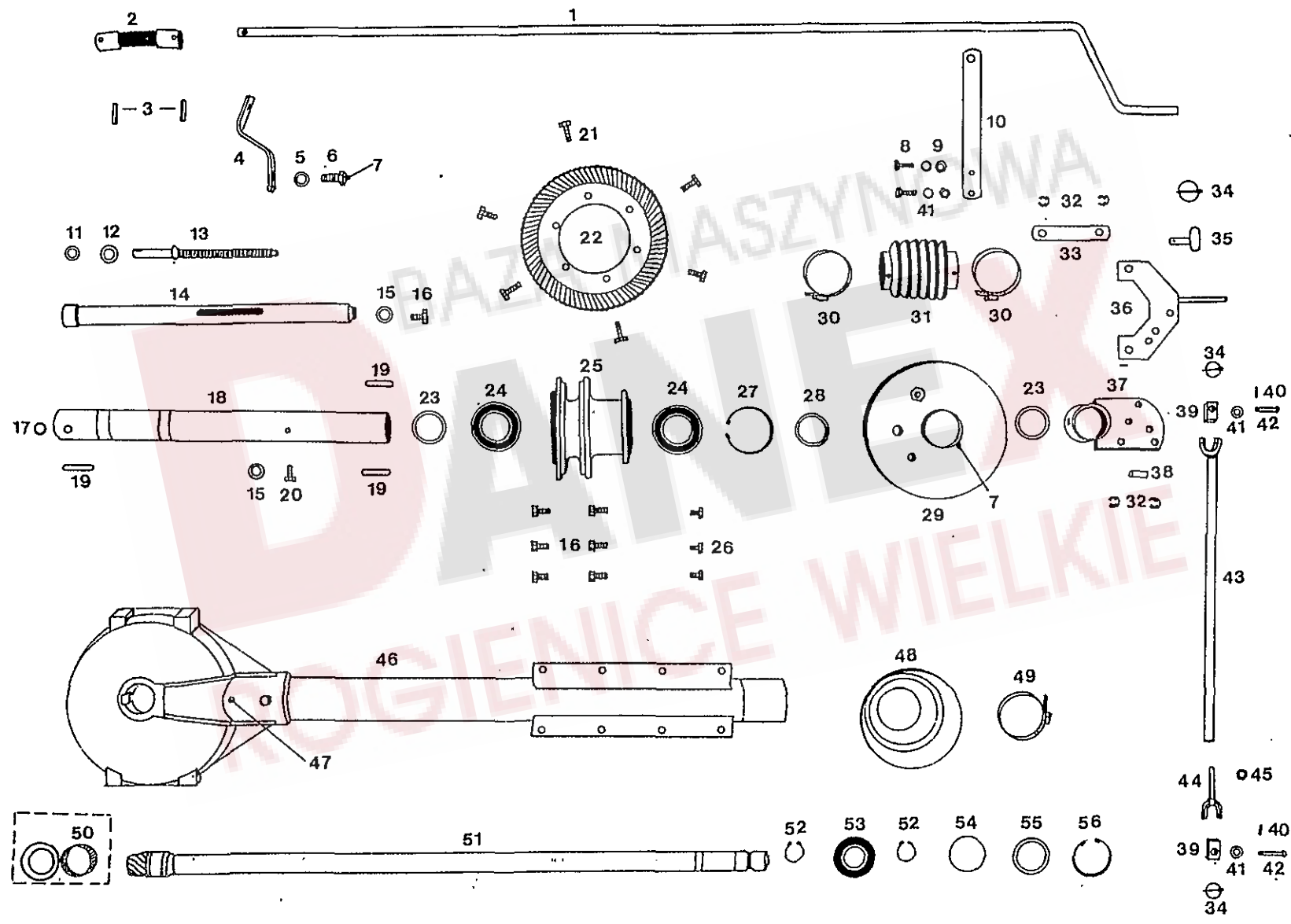

Ersatzteilliste

Tafel, Table, Plan, Tav.

3

Pos.Nr. Pos.no. Rep. Pos. no.	Bezeichnung des Teiles Description of the part. Désignation de la pièce Descrizione del pezzo	X = Verschleißteil X = weare part X = pièces d'usure	* = kein Ersatzteil * = no spare part * = no pièce de rechange	Nr. No. No. No.	TS295RDF	TS335RDF
40	Spannstift 4x20 DIN 1481 ZN 3			115 945	●	●
41	Scheibe 11 DIN 126 ZN 3			115 983	●	●
42	Scharnierniet			480 457	●	●
43	Steuerstange			492 301	●	●
43	Steuerstange			492 316G	●	●
44	Gabel			492 368G	●	●
45	6kt.-Mutter M 12 DIN 934-8 A3A			116 686	●	●
46	Rahmen			492 331G	●	●
46	Rahmen			492 894	●	●
47	Schmiernippel BS 8x1 DIN 71412			116 746	●	●
48	Gelenkwellenschutz 82.04.05				●	●
	Bezug nur durch Fa. Walterscheid		This parts can only be purchased from the Walterscheid company			
49	Schlauchschele SA 70-90 SKZ DIN 3017			117 831	●	●
50	Nadellager HK 5024 2 RS A5 1 mit Innenring 121 335			497 131	●	●
51	Getriebewelle			492 356G	●	●
52	Sicherungsring A 35x2,5 DIN 471			118 602	●	●
53	Rillenkugellager 6207 2 RS C3 DIN 625			109 585	●	●
54	Stützscheibe 56x72x3 DIN 988			124 151	●	●
54	Paßscheibe 56x72x0,3 DIN 988 (n. Bedarf)			126 368	●	●
54	Paßscheibe 56x72x0,5 DIN 988 (n. Bedarf)			126 369	●	●
54	Paßscheibe 56x72x1,0 DIN 988 (n. Bedarf)			126 370	●	●
55	Ring			490 920	●	●
56	Sicherungsring 72x2,5 DIN 472			107 385	●	●

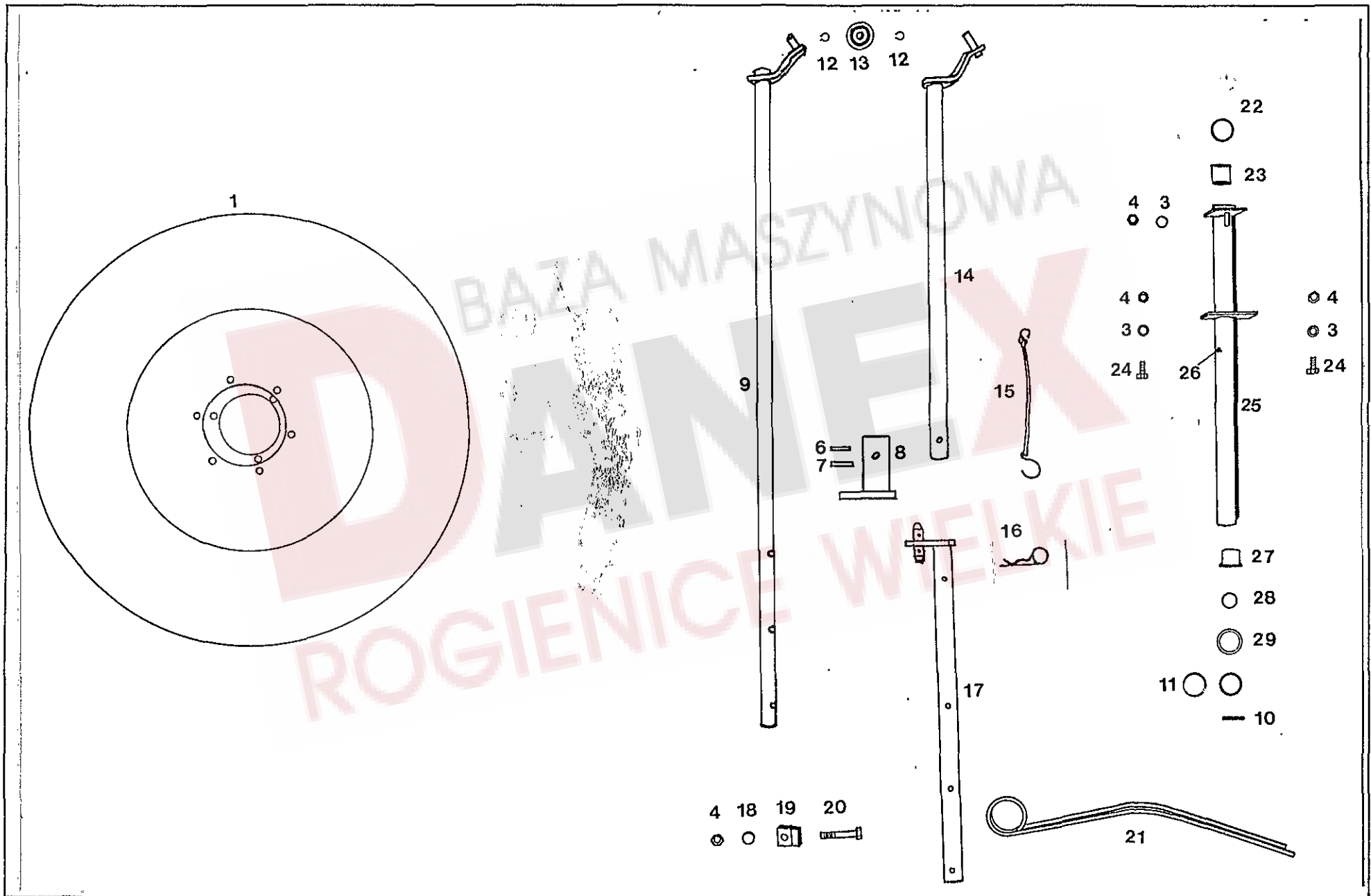

Pos.Nr. Pos.no. Rep. Pos. no.	Bezeichnung des Teiles Description of the part. Désignation de la pièce Descrizione del pezzo	X = Verschleißteil X = weare part X = pièces d'usure	* = kein Ersatzteil * = no spare part * = no pièce de rechange	Nr. No. No. No.	TS295RDF	TS335RDF
	Glocke, Zinkenträger, Lagerrohr		Dome, tine arm, tube			
1	Glocke		Dome	492 322	•	
1	Glocke		Dome	492 324G		
3	Scheibe 13 DIN 125 St ZN 3		Washer	105 186	•	•
4	Sicherungsmutter M 12 DIN 6925-8 A3A		Retaining nut	108 589	•	•
6	Spannstift 8x45 DIN 1481		Tension pin	126 880	•	•
7	Spannstift 5x45 DIN 1481		Tension pin	126 881	•	•
8	Buchse		Bush	492 838	•	•
9	Zinkenträger		Tine arm	492 973	•	
9	Zinkenträger		Tine arm	492 329		•
10	Spannstift 6x50 DIN 1481 ZN 3		Tension pin	107 454	•	
11	Paßscheibe 35x45x0,5 DIN 988 ZN 3		Fitting plate	126 375	•	•
11	Paßscheibe 35x45x1 DIN 988 ZN 3		Fitting plate	120 595	•	•
12	Sicherungsring 15x1,5 DIN 471		Snap ring	124 749	•	•
13	Kurvenrolle, vollst.		Cam roller, cpl.	497 122	X	X
14	Zinkenträger, innen		Inner tine arm	492 919	•	
14	Zinkenträger, innen		Inner tine arm	492 921		•
15	Sicherungsschnur		Safety cord	111 895	X	X
16	Federstecker		Plug	122 534	X	X
17	Zinkenträger, außen		Outer tine arm	492 920	•	•
18	Unterlage		Support	486 545	•	•
19	Zinkenhalter		Tine arm	486 848	•	•
20	6kt.-Schraube M 12x70 DIN 631-8.8 verz.		Hexagonal bolt	116 534	•	•
21	Federzinken		Flexible tine	497 031	X	
21	Federzinken		Flexible tine	497 032		X
22	Scheibe		Washer	122 731	•	•
23	Lagerbuchse m. Rand PA 6 n. DIN 7728 GV 30 + MOS 2		Bush	490 072	•	•
24	6kt.-Schraube M 12x25 DIN 933-8.8 A3A		Hexagonal bolt	116 627	•	•
25	Lagerrohr		Tube	492 924	•	
25	Lagerrohr		Tube	492 330G		•
26	Schmiernippel AM 8x1x3,5		Grease nipple	124 608	•	•
27	Lagerbuchse m. Rand PA 6 n. DIN 7728 GV 30 + MOS 2		Bush	120 725	•	•
28	Runddichtring 30x2,5 DIN 3770 - NB 70		Round seal	106 990	•	•
29	Staubkappe		Dustcap	490 961	•	•
			Cloche, toupie, bourreau			
			Cloche			
			Cloche			
			Rondelle			
			Ecrou de maintien			
			Goupille			
			Goupille			
			Douille			
			Toupie			
			Toupie			
			Goupille			
			Rondelle de fixation			
			Rondelle de fixation			
			Circlip extérieur			
			Roulette, cpl.			
			Toupie intérieur			
			Toupie intérieur			
			Cordon d'arrêt			
			Fiche			
			Toupie extérieur			
			Support en haut			
			Toupie			
			Vis à 6 pans			
			Dent flexible			
			Dent flexible			
			Rondelle			
			Douille			
			Vis à 6 pans			
			Bourreau			
			Bourreau			
			Graisseur			
			Douille			
			Bague ronde			
			Chapeau à poussière			

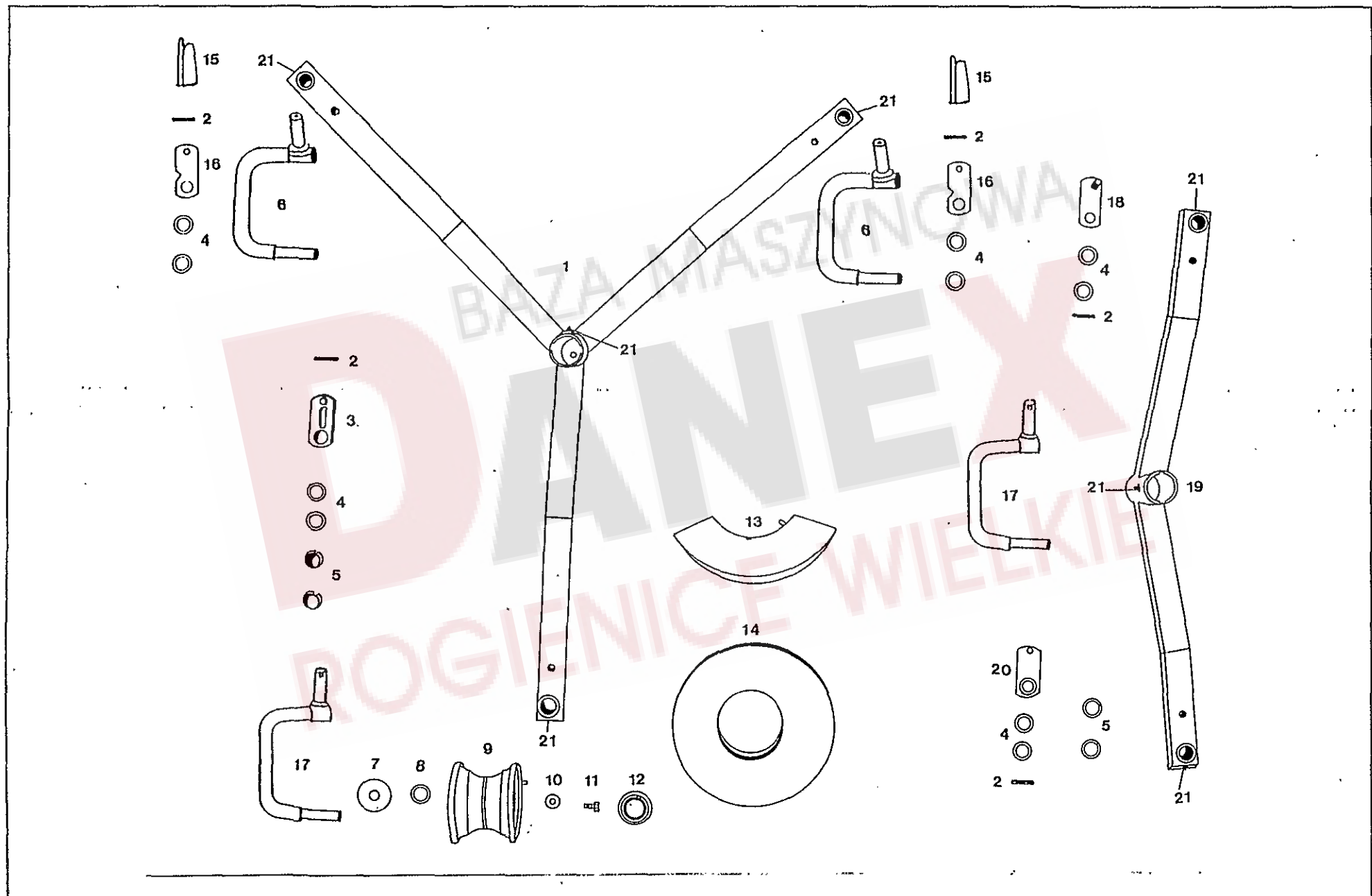

Pos.Nr.	Bezeichnung des Teiles	X = Verschleißteil	* = kein Ersatzteil	Nr.	TS295RDF	TS335RDF
Pos.no.	Description of the part.	X = weare part	* = no spare part	No.		
Rep.	Désignation de la pièce	X = pièces d'usure	* = no pièce de rechange	No.		
Pos.no.	Descrizione del pezzo			No.		
	Achsen und Laufräder		Axle and track wheel			
1	Achse		Axle	492 882		•
2	Spannstift 8x50 DIN 1481		Tension pin	107 467	•	•
3	Lasche		Tongue	492 266	•	•
4	Scheibe		Washer	224 473	•	•
5	Buchse		Bush	121 024	•	•
6	Laufachse		Carrying axle	492 415G	•	•
7	Schutzscheibe, hinten		Protective plate, rear	488 456	•	•
8	Scheibe		Washer	240 309	•	•
9	Felge 4.50 A x 6 m. 2 Rillenkugellager 6205-2 RS		Rim with grooved ball bearing	121 608	•	•
10	Scheibe		Washer	464 006	•	•
11	6kt.-Schraube M 12x20 DIN 933-8.8 A1A		Hexagonal bolt	124 331	•	•
12	Abschlußkappe		Sealing hat	121 327	•	•
13	Schlauch 140-6 TR 13		Tube	121 610	X	X
14	Decke 15x6.00-6 Impl. 4 PR-T510		Surface	121 609	X	X
15	Federsteckbolzen 12x65		Clip-on bolt	120 760	X	X
16	Lasche		Tongue	492 270	•	•
17	Laufachse		Carrying axle	492 271G	•	•
18	Lasche		Tongue	492 320G	•	•
19	Achse		Axle	492 881	•	•
20	Lasche		Tongue	492 319	•	•
21	Schmiernippel AM 8x1 DIN 71412 SFG		Grease nipple	108 292	•	•

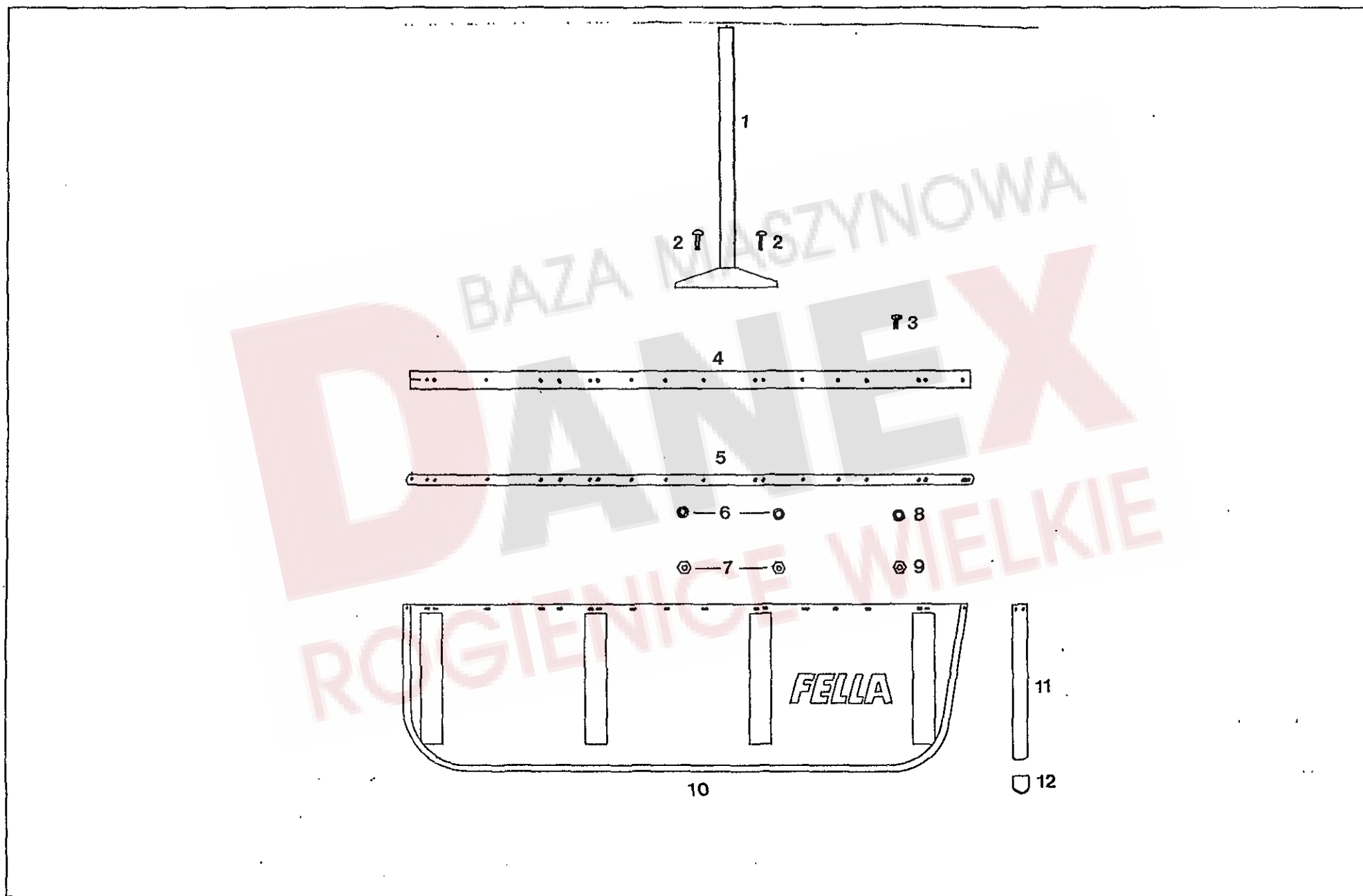

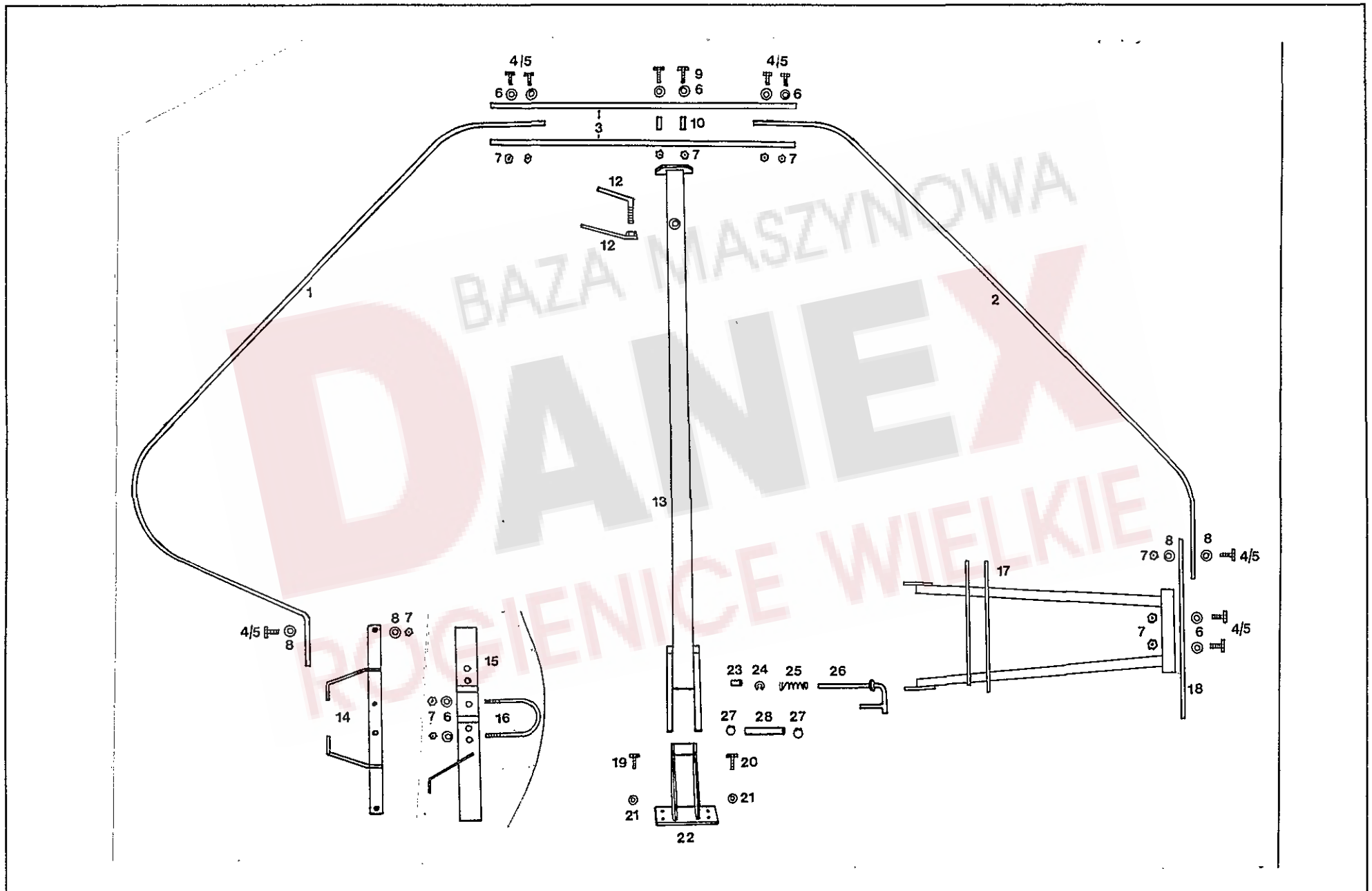

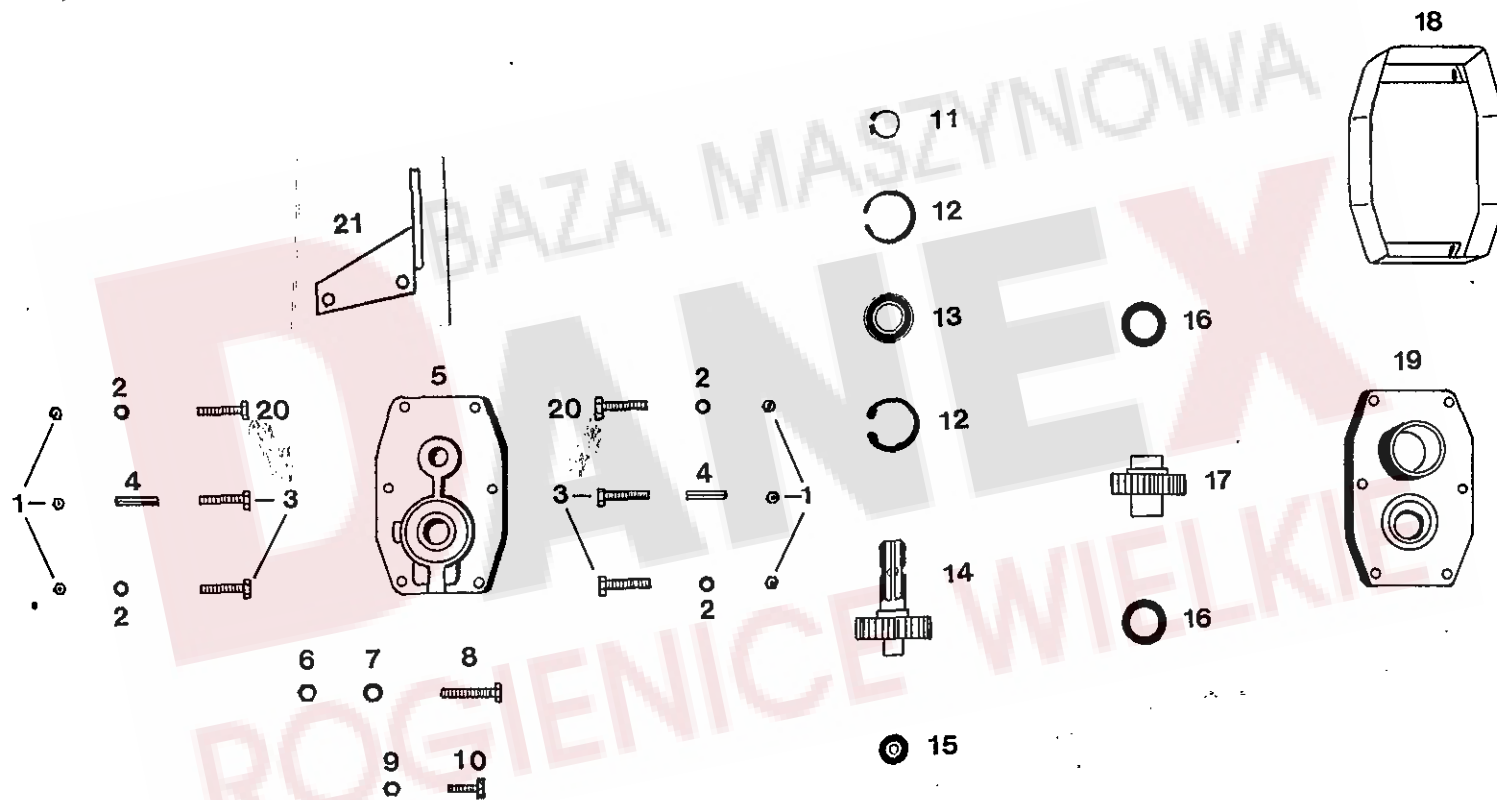

Pos.Nr.	Bezeichnung des Teiles	X = Verschleißteil	* = kein Ersatzteil	Nr.	540:540	1000:540	540:400	1000:400
Pos.no.	Description of the part.	X = weare part	* = no spare part	No.				
Rep.	Désignation de la pièce	X = pièces d'usure	* = no pièce de rechange	No.				
Pos. no.	Descrizione del pezzo			No.				
	Sonderzubehör Umkehrgetriebe		Special equipment reversing gear					
			Equipement special renversement					
1	Sicherungsmutter M 8 DIN 6925-8 A3A		Retaining nut	108 531	•	•	•	•
2	Scheibe 8,4 DIN 125 St ZN 3		Washer	115 972	•	•	•	•
3	Zylinderschraube M 8x70 DIN 912-8.8 A3A		Intermediate pipe	127 035	•	•	•	•
4	Spannstift 11x45 DIN 7346 ZN 3		Tension pin	126 340	•	•	•	•
5	Getriebegehäuse		Gearbox housing	492 293	•	•	•	•
6	Sicherungsmutter M 12 DIN 6925-10 A3A		Retaining nut	124 710	•	•	•	•
7	Scheibe 13 DIN 125 St ZN 3		Washer	105 186	•	•	•	•
8	6kt.-Schraube M 12x70 DIN 931-10.9 A3A		Hexagonal bolt	109 458	•	•	•	•
9	6kt.-Mutter M 10 DIN 934-8 A3A		Hexagonal nut	116 685	•	•	•	•
10	6kt.-Schraube BM 10x35 DIN 564-8.8 A3A		Hexagonal bolt	126 721	•	•	•	•
11	Sicherungsring A 35x2,5 DIN 471		Snap ring	118 602	•	•	•	•
12	Sicherungsring M 62x2 DIN 472		Snap ring	107 383	•	•	•	•
13	Rillenkugellager 6007-2 RS DIN 625		Grooved ball bearing	126 429	•	•	•	•
14	Getriebewelle		P.t.o.-shaft	121 933	•			
14	Getriebewelle		P.t.o.-shaft	121 932		•		
14	Getriebewelle		P.t.o.-shaft	122 027			•	
14	Getriebewelle		P.t.o.-shaft	121 931				•
15	Nadelbüchse BK 3020 DIN 618		Needle case	126 337	•	•	•	•
16	Wellendichtring A 45x62x8 DIN 3760-NB		Seal	116 774	•	•	•	•
17	Stirnrad		Spur wheel	121 936	•			
17	Stirnrad		Spur wheel	121 935		•		
17	Stirnrad		Spur wheel	122 026			•	
17	Stirnrad		Spur wheel	121 934				•
18	Schutz		Guard	122 424	•	•	•	•
19	Getriebedeckel		Gearbox cover	492 294	•	•	•	•
20	6kt.-Schraube M 8x80 DIN 931-8.8 A3A		Hexagonal bolt	124 915	•	•	•	•
21	Stütze		Support	497 051	•	•	•	•

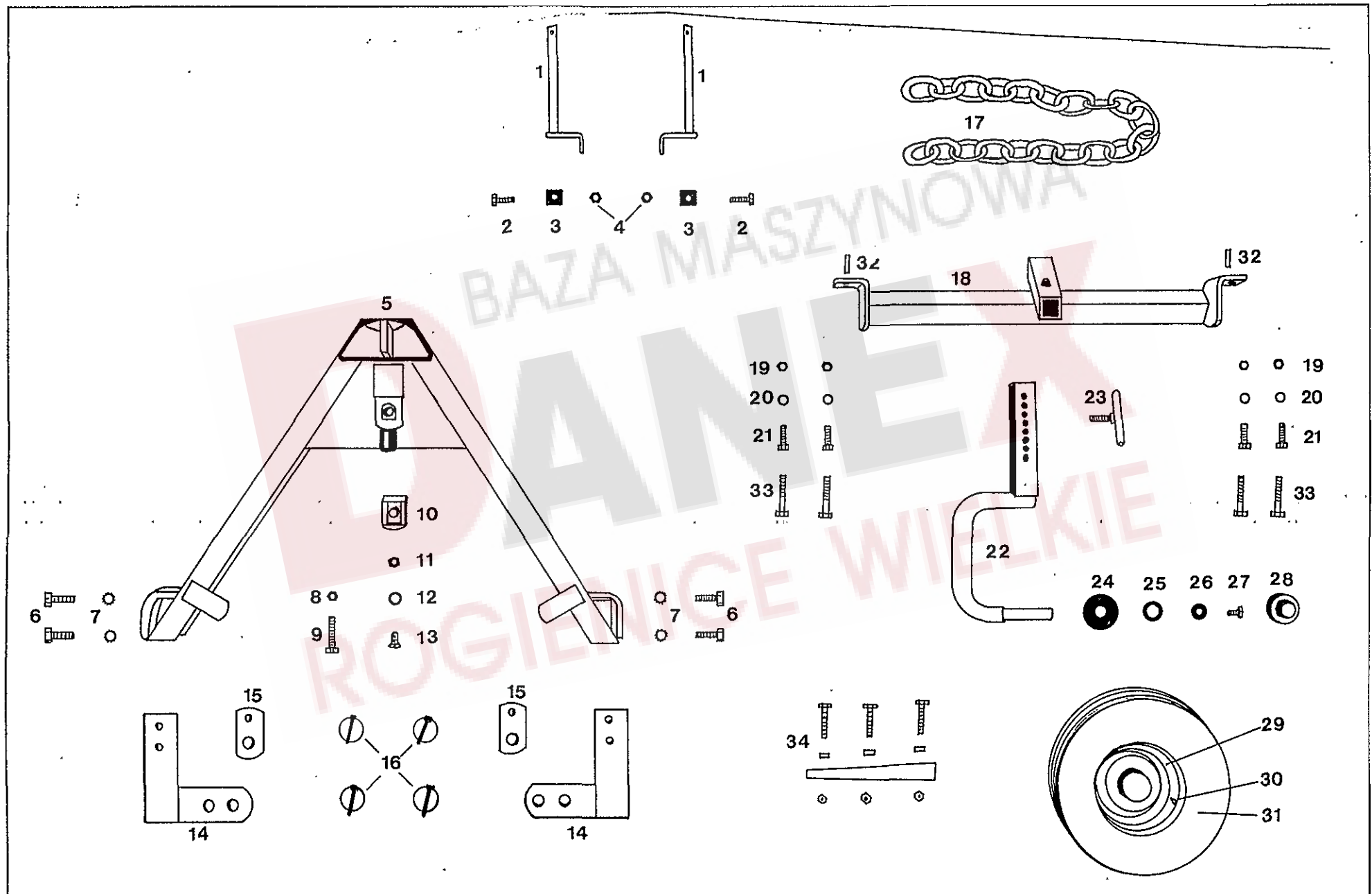

Pos.Nr. Pos.no. Rep. Pos.no.	Bezeichnung des Teiles Description of the part. Désignation de la pièce Descrizione del pezzo	X = Verschleißteil X = wear part X = pièces d'usure	* = kein Ersatzteil * = no spare part * = no pièce de rechange	Nr. No. No. No.	TS295RDF	TS335RDF		
	SONDERZUBEHÖR							
	Satz Beleuchtungshalter							
1	Beleuchtungshalter			492 633G	●	●		
2	6kt.-Schraube M 10x35 DIN 933-8.8 A1A			116 623G	●	●		
3	Scheibe			492 632	●	●		
4	Sicherungsmutter M 10 DIN 6925-8 A1A			108 441	●	●		
	Geräte-Dreieck							
5	Geräte-Dreieck			476 165G	●	●		
6	6kt.-Schraube M 16x1,5x40 DIN 961-10.9			118 596	●	●		
7	Zahnscheibe A 16,5 DIN 6797 ZN 3			116 053	●	●		
8	6kt.-Mutter M 12 DIN 934 A1A			116 686	●	●		
9	6kt.-Schraube M 12x60 DIN 933-8.8 A1A			117 726	●	●		
10	Schieber			121 735	●	●		
11	6kt.-Mutter M 12 DIN 936-8 A1A			118 097	●	●		
12	Scheibe 13 DIN 125 ZN 3			105 186	●	●		
13	Senkschraube M 12x25 DIN 7991-8.8 A1A			124 980	●	●		
14	Lasche			492 263G	●	●		
15	Lasche			492 107	●	●		
16	Klappstecker 10 DIN 11023 ZN 3			108 671	X			
	Stützrad, vollst.							
17	Kette 18x52 DIN 5685 verz.			126 228G	●	●		
18	Träger			492 639G	●	●		
19	Sicherungsmutter M 12 DIN 6925-8 A1A			108 589	●	●		
20	Scheibe 13 DIN 125 ZN 3			105 186	●	●		
21	6kt.-Schraube M 12x40 DIN 931-8.8 A1A			116 630	●	●		
22	Laufachse			492 643G	●	●		
23	Knebelschraube			477 269G	●	●		
24	Schutzscheibe, hinten			487 652	●	●		
25	Scheibe			240 309	●	●		
26	Scheibe			464 006	●	●		
27	6kt.-Schraube M 12x20 DIN 933-8.8 A1A			124 331	●	●		
28	Abschlußkappe			121 327	●	●		
29	Felge 4.50 Ax6 m. 2 Rillenkugellagern 6205-2 RS			121 608	●	●		
30	Decke 15x6.00-6 Impl. 4 PR-T 510			121 609	X	X		
31	Schlauch 140-6 TR 13			121 610	X	X		
32	Distanzstück			492 829	●	●		
33	6kt.-Schraube M 12x120 DIN 931-8.8 A1A			116 539	●	●		
34	Garnitur Unterlegkeile			492928	●	●		

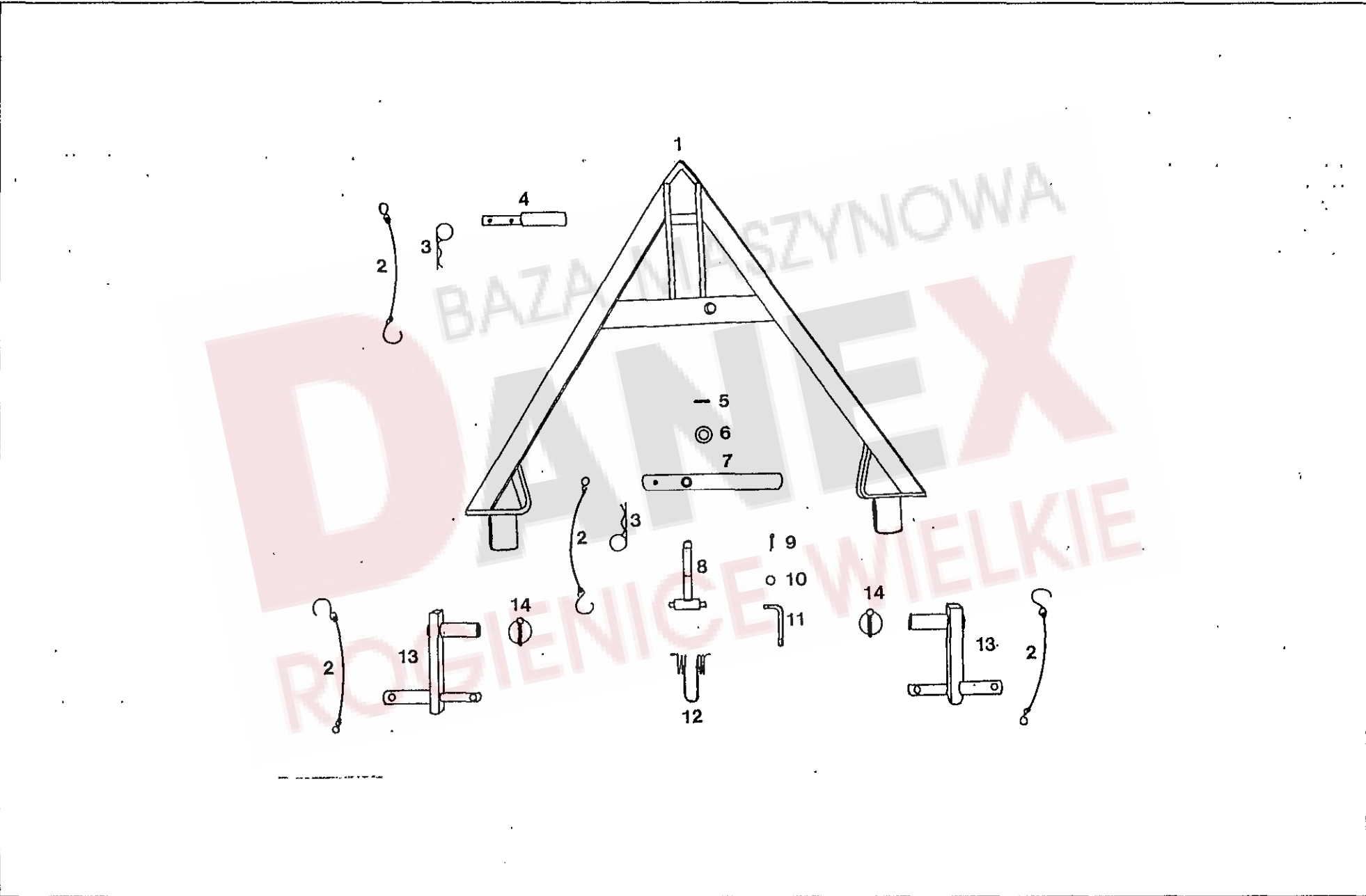

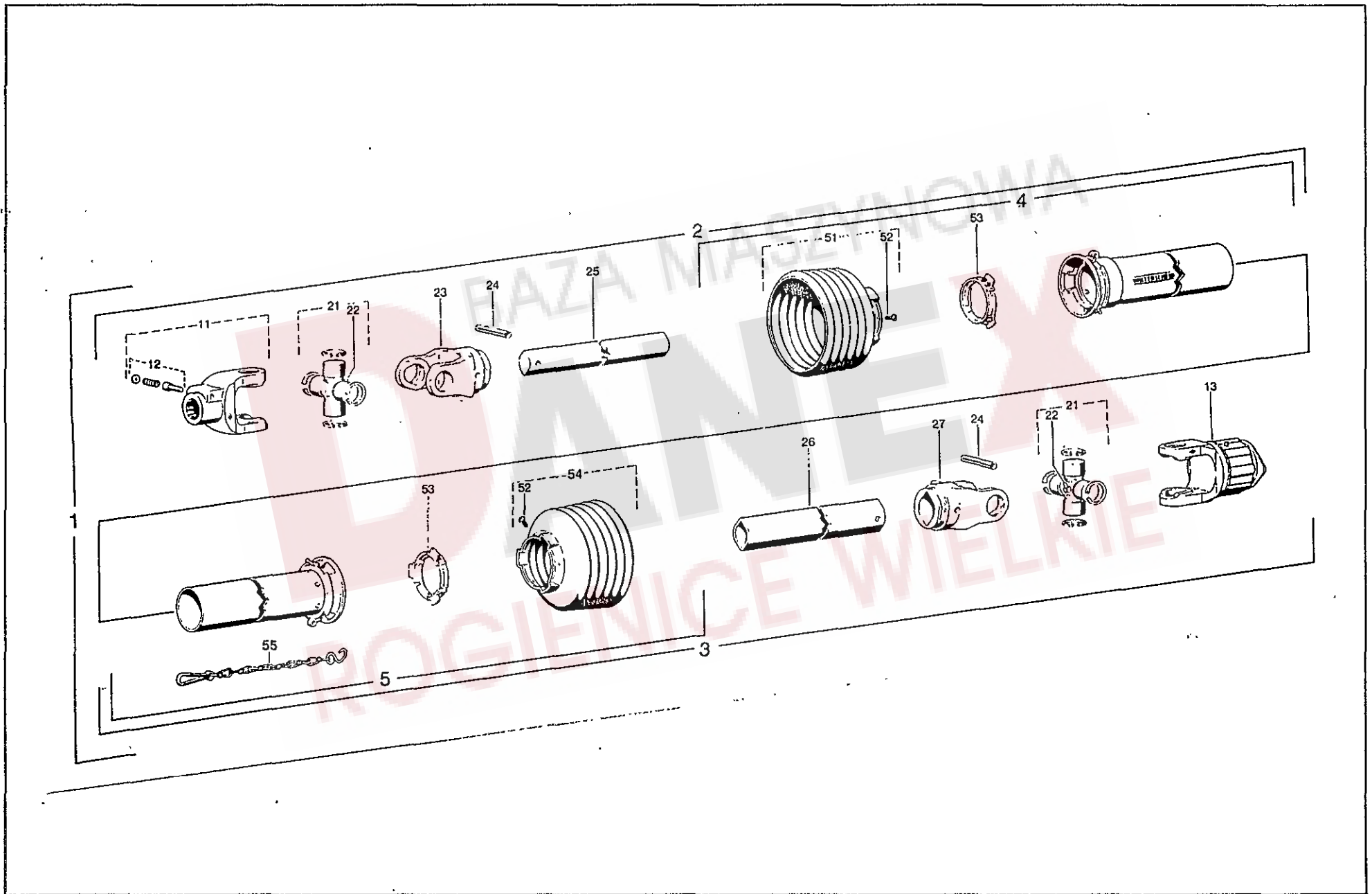

Pos.Nr. Pos.no. Rep. Pos.no.	Bezeichnung des Teiles Description of the part Désignation de la pièce Descrizione del pezzo			Nr. No. No. No.
	Gelenkwelle W 2100-SC05-910-K32B TS 295/335 RDF	P.t.o.-schaft	Transmission	
1	Gelenkwelle mit Schutz W 2100-SC05-910-K32B	PTO drive shaft with guard	Transmission avec protecteur	184 768
2	Innere Gelenkwellenhälfte mit äußerer Schutzhälfte WH 2100-SC05-856	Inner PTO drive shaft half with outer guard half	Demi-transmission intérieure avec demi-protecteur extérieur	333 501
3	Äußere Gelenkwellenhälfte mit innerer Schutzhälfte WH 2100-SC05-841-K32B	Outer PTO drive shaft half with inner guard half	Demi-transmission extérieure avec demi-protecteur intérieur	184 753
4	Äußere Schutzhälfte SCH05-A750-RP6-K	outer guard half	Demi-protecteur extérieur	368 024
5	Innere Schutzhälfte SCH05-J750-RP10-K	Inner guard half	Demi-protecteur intérieur	170 958
11	Aufsteckgabel, kompl. AG 2100-1 3/8" (6)	Quick-disconnect yoke complete	Mâchoire à verrouillage rapide cpl.	040 154
12	Schiebestift, kompl.	Quick-disconnect pin complete	Poussoir de verrouillage rapide cpl.	339 107
13	Sternratsche, kompl., drehsinnunabhängig K32B-2100-1 3/8" (6) ZV M=400 Nm	Radial pin clutch cpl. independent of direction of rotation	Limiteur à cames en étoile cpl. indépendant du sens de rotation	351 075
21	Kreuzgarnitur, kompl.	Cross and bearing kit, cpl.	Bloc croisillon, cpl.	040 116
22	Kegelschmiernippel M 8x1	Lubrication fitting	Graisser	084 099
23	Rillengabel RG 2100-00a	Inboard yoke	Mâchoire à gorge	040 444
24	Spannstift DIN 1481 8x50	Spring type straight pin	Goupille élastique	020 600
25	Profilwelle 00a-820	Profile shaft	Arbre profilé	322 367
26	Profilrohr 0a-805	Profile tube	Tube profilé	054 622
27	Rillengabel RG 2100-0a	Inboard yoke	Mâchoire à gorge	040 456
51	Schutztrichter mit Schraube n=RP5	Guard cone with screw	Cône protecteur avec vis	365 258
52	Schraube 4x10	Screw	Vis	365 305
53	Gleitring	Bearing ring	Bague de glissement	359 005
54	Schutztrichter mit Schraube N=RP8	Guard cone with screw	Cône protecteur avec vis	365 261
55	Haltekette	Safety chain	Chaînette	044 321
	Ersatzteil können nur über die Firma Walterscheid bezogen werden.	These parts are not supplied by FELLA. They can only be purchased directly from the Walterscheid company.	Cette pièces peuvent seule- ment être achetées chez la maison Walterscheid	

Ersatzteilliste

NUMMERNVERZEICHNIS
INDEX OF NUMBERS

LIST NUMERIQUE
INDICE PER NUMERI

Bestell-Nr. Part no No de commande No d'ordinazione	Tafel Table Tableau Tavola	Pos.-Nr. Pos.-no No de pos. Pos. No	Bestell-Nr. Part no No de commande No d'ordinazione	Tafel Table Tableau Tavola	Pos.-Nr. Pos.-no No de pos. Pos. No	Bestell-Nr. Part no No de commande No d'ordinazione	Tafel Table Tableau Tavola	Pos.-Nr. Pos.-no No de pos. Pos. No	Bestell-Nr. Part no No de commande No d'ordinazione	Tafel Table Tableau Tavola	Pos.-Nr. Pos.-no No de pos. Pos. No
105 186	1.17 7.21	3.15 4.03 9.12 9.20	116 686	2.25 3.45	9.08	122 731	4.22		487 652	9.24	
105 421	6.06		116 746	3.47		124 131	3.12		488 456	5.07	
106 857	1.02		116 774	8.16		124 151	3.54		490 072	4.23	
106 903	6.09		117 245	14.12	2.24	124 331	3.26	5.11 9.27	490 920	3.55	
106 990	4.28		117 726	2.26	9.09	124 453	6.02		490 961	4.29	
107 383	8.12		117 831	3.30	3.49	124 608	3.07	4.26	492 104	7.12	
107 385	3.56		118 097	2.27	9.11	124 650	3.23		492 107	9.15	
107 438	10.05		118 596	9.06		124 710	1.10	2.05 8.06	492 113	6.04	
107 453	1.05		118 602	3.52	8.11	124 749	4.12		492 114	6.05	
107 454	4.10		118 604	3.24		124 826	3.32	7.24	492 119	6.01	
107 464	3.03		118 973	2.06		124 915	8.20		492 255	3.25	
107 467	5.02		120 725	4.27		124 980	2.19	9.13	492 263	9.14	
107 735	2.18	7.04	120 760	5.15		126 228	9.17		492 266	5.03	
108 292	5.21		120 777	7.25		126 301	7.20		492 267	1.11	
108 294	2.09		121 024	2.12	5.05	126 302	3.28		492 270	5.16	
108 319	3.19		121 327	5.12	9.28	126 303	3.21		492 271	5.17	
108 441	2.17	3.09 7.07 9.04	121 608	5.09	9.29	126 308	2.03	3.16 7.19	492 288	3.39	
108 531	6.07		121 609	5.14	9.30	126 337	8.15		492 293	8.05	
108 544	1.14	10.14	121 610	5.13	9.31	126 340	8.04		492 294	8.19	
108 589	1.04	4.04 9.19	121 611	6.10		126 368	3.54		492 298	6.05	
108 671	9.16		121 612	6.11		126 369	3.54		492 299	6.04	
108 745	2.22		121 735	2.28	9.10	126 370	3.54		492 301	3.43	
109 162	3.34		121 914	3.22		126 375	4.11		492 312	1.07	
109 458	8.08		121 931	8.14		126 383	1.08	2.02	492 316	3.43	
109 585	3.53		121 932	8.14		126 384	3.23		492 318	3.37	
111 895	1.01	4.15 10.02	121 933	8.14		126 385	3.23		492 319	5.20	
115 905	10.09		121 934	8.17		126 417	3.17		492 320	5.18	
115 916	1.15	2.20 10.03	121 935	8.17		126 429	8.13		492 322	4.01	
115 945	3.40		121 936	8.17		126 530	7.23		492 324	4.01	
115 970	6.08		121 968	6.10		126 585	1.09		492 330	4.25	
115 972	8.02	10.10	121 970	3.02		126 644	7.27		492 331	3.46	
115 979	3.05	10.06	121 988	10.12		126 721	8.10		492 356	3.51	
115 983	3.41	7.06	121 990	3.31		126 771	2.01		492 359	3.04	
116 024	3.11		121 993	3.38		126 825	7.08		492 361	3.06	
116 043	3.27		122 026	8.17		126 880	4.06		492 366	3.36	
116 053	9.07		122 027	8.14		126 881	4.07		492 367	3.36	
116 519	7.09		122 079	3.20		126 929	2.08		492 368	3.44	
116 534	4.20		122 103	6.12		127 035	8.03		492 385	1.13	10.13
116 539	9.33		122 292	7.11		224 473	2.07	5.04	492 393	1.06	
116 608	6.03		122 394	7.10		240 309	5.08	9.25	492 405	10.11	
116 623	3.08	7.05 9.02	122 424	8.18		464 006	2.15	5.10 9.26	492 404	10.07	
116 627	4.24		122 461	7.16		476 165	9.05		492 407	10.08	
116 628	1.03		122 466	2.19		477 269	9.23		492 411	10.01	
116 630	2.16	9.21	122 473	2.23		480 457	3.42		492 415	5.06	
116 685	8.09		122 534	4.16		486 545	4.18		492 419	3.35	
			122 613	1.16	10.04	486 848	4.19		492 420	3.33	