



**FELLA**

# Turboschwader

- Ⓓ Ersatzteilliste
- Ⓕ Liste de Pièces de Rechange
- ⒼⒸ Spare Parts List

**TS 880 PRO**  
ab Masch.-Nr. AAD 00101

Ausgabe - Edition - Edition

049/1

04/09

166 267

## **D** ERSATZTEILLISTE

### WICHTIG BEI BESTELLUNG VON ERSATZTEILEN

Für das zu ersetzende Teil ist anhand der nachfolgenden Ersatzteilliste die genaue Bestell-Nummer und die Bezeichnung festzustellen.

Besonders aber bitten wir um Angabe des auf dem Typenschild eingepprägten Maschinen-Typen und der Maschinen-Nummer, um Fehllieferungen von Ersatzteilen zu vermeiden. Die genaue Anschrift sowie Versandart (per Post, Paketdienst, Nachtexpress oder Spedition Ihrer Wahl) ist unbedingt anzugeben.

Die in der Ersatzteilliste mit "X" gekennzeichneten Ersatzteile unterliegen während des Betriebes natürlichem Verschleiß und sind daher von der Garantie ausgenommen. Vor jedem Einsatz ist die Überprüfung der Funktionsfähigkeit dieser Teile erforderlich. Gegebenenfalls muss der Austausch erfolgen. Für Folgeschäden, die durch nicht rechtzeitiges Auswechseln von Verschleißteilen entstehen, besteht kein Garantieanspruch.

## **F** CATALOGUE DES PIÈCES DE RECHANGE

### NOTE IMPORTANTE RELATIVE AUX COMMANDES DE PIÈCES DÉTACHÉES

Déterminez le numéro exact de référence et la désignation de la pièce à échanger, en consultant la liste suivante des pièces de rechange, s.v.p.

Nous vous demandons en particulier, pour éviter les erreurs dans les livraisons en pièces détachées, de bien indiquer le numéro de la série du type de la machine, qui est marqué sur la plaque du constructeur, ainsi que le numéro de la machine. Toujours indiquer l'adresse avec précision, ainsi que le mode d'expédition choisi (par voie postale, par petit paquet, par colis postal, en service express de nuit, ou par un autre mode d'expédition que ceux ci-dessus cités).

Les pièces de rechange marquées "X" dans la liste des pièces de rechange sont soumises à l'usure par détérioration naturelle pendant le service, et pour cela ne sont pas couvertes par notre garantie. Avant toute utilisation, il faut contrôler le bon fonctionnement de ces pièces. Si nécessaire, il faut les remplacer. Nous ne pouvons pas accepter de garantie pour dommages consécutifs résultant du fait que les pièces d'usure n'ayent pas été remplacées au bon moment.

## **GB** SPARE PARTS CATALOGUE

### IMPORTANT NOTE CONCERNING ORDERS ON SPARE PARTS

Please use the following spare parts list in order to identify the part to be replaced, and quote its exact part number and description. In particular, you are requested to quote machine type and machine no. indicated marked on the nameplate, in order to prevent supply of wrong parts. Please always mention your complete address as well as kind of transport (post parcel, parcel service, overnight express or forwarding agency according to your choice).

The spare parts marked "X" in the spare parts list are subject to normal wear and tear during operation, and therefore are not covered by our warranty. Prior to every work these parts must be checked for perfect operation. If necessary, they have to be replaced. We cannot accept any warranty for consequential damage which is due to the fact that wear parts have not replaced in proper time.

## **NL** ONDERDELENLIJST

### BELANGRIJK VOOR HET BESTELLEN VON ONDERDELEN

Volgens bijgaande onderdelenlijst is het juiste bestelnummer en de omschrijving van het te vervangen deel vast te stellen.

In het bijzonder vragen wij U, het op het typeplaatje ingestempelde machinetype en machinenummer op te geven, om foutieve leveringen van onderdelen te vermijden. Beslist noodzakelijk is het vermelden van het juiste adres, met postkantoor of NS-station en postcode, alsmede de verzendingswijze (pakje, postpakket, vracht-, ij- of expresgoed).

De onderdelen, die in de onderdelenlijst met een "X" zijn gemerkt, zijn tijdens het gebruik onderhevig aan normale slijtage en vallen daarom niet onder de garantiebepalingen. De toestand van deze delen dient, telkens vóór het werk begint, te worden gecontroleerd op hun goede werking. Zonodig versleten delen vervangen. Eventuele schade, tengevolge van niet tijdige vervanging van versleten onderdelen, wordt niet door de garantie gedekt.

## **I** LISTINO RICAMBI MACCHINE FELLA

### NOTE IMPORTANTI PER ORDINI DI RICAMBI

Individuare l'esatto codice ricambi composto da 6 cifre e la denominazione del ricambio da ordinare consultando il seguente listino ricambi.

Per evitare inconvenienti, Vi preghiamo di indicare inoltre la matricola della macchina e l'anno di costruzione. Ogni macchina ha una targhetta, dove sono incisi questi dati. Indispensabile per ogni ordine sono anche il Vs. indirizzo completo e la modalità di trasporto (tramite poste, corriere espresso, notturno oppure una ditta di spedizione ai Vostra scelta).

I ricambi contraddistinti con la lettera "x" sono ricambi a largo consumo e soggette a naturale usura. Per questi ricambi non è prevista alcuna garanzia. Preghiamo controllare con attenzione la funzionalità dei ricambi a largo consumo prima di iniziare il lavoro. In caso necessario procedere all'immediata sostituzione. La ditta FELLA WERKE GmbH & Co. KG non si assume alcuna responsabilità per danni sorti per la non tempestiva sostituzione di questi ricambi.

## **E** LISTA DE PIEZAS DE RECAMBIO

### IMPORTANTE PARA PEDIR PIEZAS DE RECAMBIO

Averiguar n° ref. y denominación exacta de la pieza a recambiar usando la lista de recambio siguiente.

Les rogamos especialmente indicarnos tipo y número de la máquina, estampados en la placa indicador para evitar el suministro de piezas de recambio incorrectas. Siempre mencionar la dirección exacta y el modo de envío (correo, servicio de paquetes, reparto urgente o agencia de expedición según su deseo).

Las piezas marcadas por "X" en la lista de recambio son piezas de desgaste y por eso no forman parte de nuestra garantía. Antes de cada empleo de la máquina hay que revisar la función de estas piezas. En caso de necesidad hay que reemplazarlas. Daños que resultan del recambio retrasado de estas piezas no forman parte de nuestra garantía.

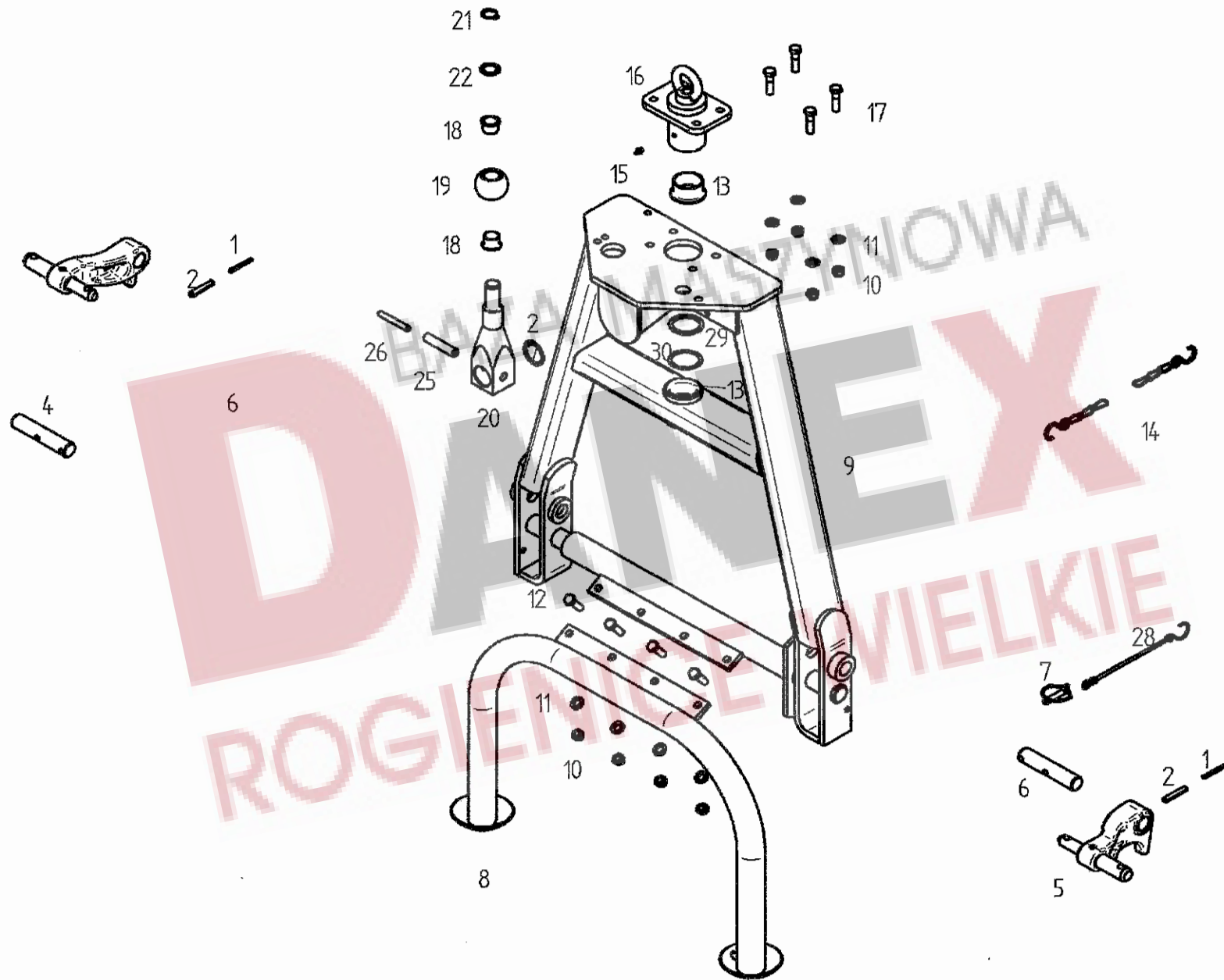

E00013 - 02		Schwenkbock		Swivelling device	
		ET =	Ersatzteil	Spare part	
		EV =	Verschleißteil	Wear part	
POS:	TeilNr	Status	Benennung	Description	ET-Tech-Daten
1	127253	ET	Spannstift	Tensioning pin	ISO 8752 6x55-A-St DAC
2	127252	ET	Spannstift	Tensioning pin	ISO 8752 10x55-A-St DAC
4	164323	ET	Unterlenkerhebel	Lower link lever	
5	164299	ET	Unterlenkerhebel	Lower link lever	
6	162173	ET	Bolzen	Pin	
7	108671	ET	Klappstecker	Folding plug	DIN 11023 10x45 ZN3
8	164640	ET	Abstellstütze	Parking support	
9	163683	ET	Schwenkbock mit Lagerbuchse	Swiveling device with bushings	
10	108589	ET	6kt-Mutter	Nut	DIN 985 M12- 8 AOC
11	105186	ET	Scheibe	Washer	DIN 125 - 13 AOC
12	116630	ET	6kt-Schraube	Hexagonal bolt	DIN 933 M12x 40- 8.8 AOC
13	161098	ET	Bundbuchse	Flange sleeve	
14	117245	ET	Kette	Chain	DIN 5686 2.8X960 22Gl. tZn
15	108292	ET	Kegeleschmiernippel	Conical grease nipple	DIN 71412 A S8X1
16	162765	ET	Lagerbuchse	Bearing bush	
17	126771	ET	6kt-Schraube	Hexagonal bolt	DIN 931 M12x 45- 8.8 AOC
18	162619	ET	Bundbuchse	Flange sleeve	
19	161168	ET	Kugel	Ball	
20	162607	ET	Lenkhebel	Steering lever	
21	118597	ET	Sicherungsring	Snap ring	DIN 471 25x2
22	127570	ET	Passscheibe	Adjusting washer	DIN 988 25x36x2
25	127972	ET	Spannstift	Tensioning pin	ISO 8752 16x75-A-St DAC
26	127973	ET	Spannstift	Tensioning pin	ISO 8752 10x75-A-St DAC
27	127572	ET	Passscheibe	Adjusting washer	DIN 988 40x50x1.5
28	111895	ET	Sicherungsschnur mit Haken	Safety cord	
29	124330	ET	Stützscheibe	Supporting plate	DIN 988 S 50x62x3
30	127807	ET	Passscheibe	Adjusting washer	DIN 988 50x62x1

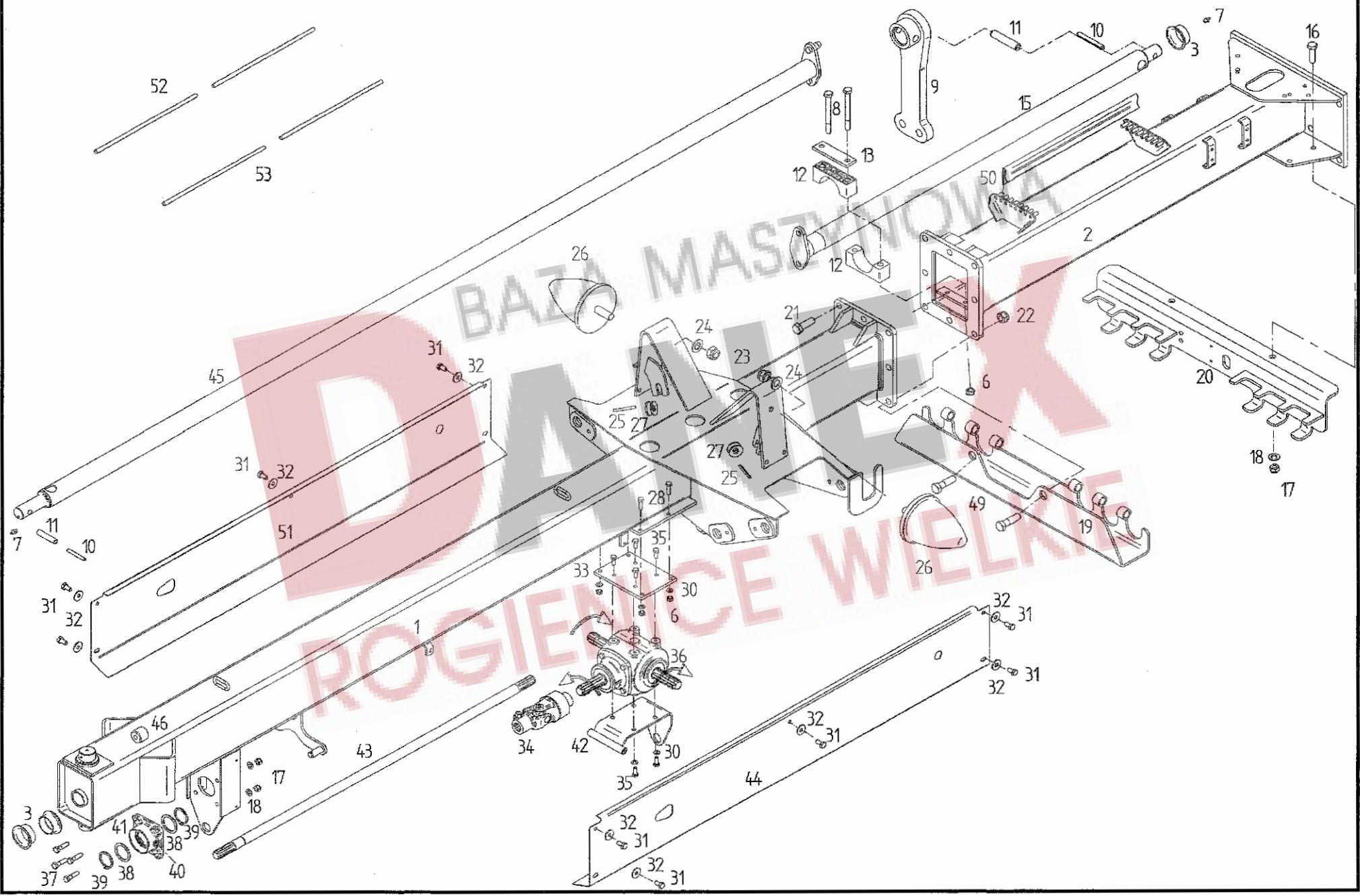

E00014 - 01		Rahmen		Frame	
		ET =	Ersatzteil	Spare part	
		EV =	Verschleißteil	Wear part	
POS.	TeilNr	Status	Benennung	Description	ET-Tech-Daten
1	166016	ET	Rahmen	Frame	
2	165689	ET	Rahmen	Frame	
3	161159	ET	Bundbuchse	Flange sleeve	
6	108441	ET	6kt-Mutter	Nut	DIN 985 M10- 8 A0C
7	108292	ET	Kegelschmiernippel	Conical grease nipple	DIN 71412 A S8X1
8	116459	ET	6kt-Schraube	Hexagonal bolt	DIN 931 M10x100- 8.8 A0C
9	162672	ET	Lenkhebel	Steering lever	
10	127973	ET	Spannstift	Tensioning pin	ISO 8752 10x75-A-St DAC
11	127972	ET	Spannstift	Tensioning pin	ISO 8752 16x75-A-St DAC
12	164596	ET	Lagerschale	Bearing shell	
13	162078	ET	Platte	Plate	
15	163909	ET	Lenkwelle	Steering shaft	
16	116630	ET	6kt-Schraube	Hexagonal bolt	DIN 933 M12x 40- 8.8 A0C
17	108589	ET	6kt-Mutter	Nut	DIN 985 M12- 8 A0C
18	105186	ET	Scheibe	Washer	DIN 125 - 13 A0C
19	164171	ET	Ablageprofil	Support profile	
20	164181	ET	Ablageprofil	Support profile	
21	128204	ET	6kt-Schraube	Hexagonal bolt	DIN 961 M20x1.5x 60- 8.8 A0C
22	128190	ET	6kt-Mutter	Nut	DIN 985 M20x1.5- 8 A0C
23	116699	ET	6kt-Mutter	Nut	DIN 985 M16- 8 A0C
24	115979	ET	Scheibe	Washer	DIN 125 - 17 A0C
25	127399	ET	Spannstift	Tensioning pin	ISO 8752 5x50-A-St DAC
26	166017	ET	Parabelfeder	Parabola spring	
27	127516	ET	Seilrolle	Rope pulley	
28	116623	ET	6kt-Schraube	Hexagonal bolt	DIN 933 M10x 35- 8.8 A0C
30	115973	ET	Scheibe	Washer	DIN 125 - 10.5 A0C
31	127933	ET	6kt-Schraube	Hexagonal bolt	DIN 933 M 8x 16- 8.8 A0C Vpl
32	105421	ET	Scheibe	Washer	DIN 9021 - 8.4 A0C
33	161055	ET	Platte	Plate	
34	165945	ET	Kreuzgelenk	Universal joint	
35	124508	ET	6kt-Schraube	Hexagonal bolt	DIN 933 M10x 25- 8.8 A0C Vpl
36	162386	ET	Getriebe	Gearbox	
37	126771	ET	6kt-Schraube	Hexagonal bolt	DIN 931 M12x 45- 8.8 A0C
38	126242	ET	Stützscheibe	Supporting plate	DIN 988 S 35x45x2.5
39	118602	ET	Sicherungsring	Snap ring	DIN 471 35x2.5
40	128292	ET	Kegelschmiernippel	Conical grease nipple	DIN 71412 A M6x1
41	163797	ET	Lager-Gehäuseeinheit	Bearing assembly	
42	164184	ET	Halter	Support	
43	165979	ET	Antriebswelle	Drive shaft	
44	165978	ET	Schutzblech	Wheel guard	Left
45	162134	ET	Lenkwelle	Steering shaft	
46	163986	ET	Buchse	Bushing	
49	128191	ET	6kt-Schraube	Hexagonal bolt	DIN 960 M20x1.5x 70- 8.8 A0C
50	164295	ET	Klemmprofil	Profile clamp	
51	166027	ET	Schutzblech	Wheel guard	Right
52	161459	ET	Seil	Rope	
53	123389	ET	Seil	Rope	

E00015 - 01

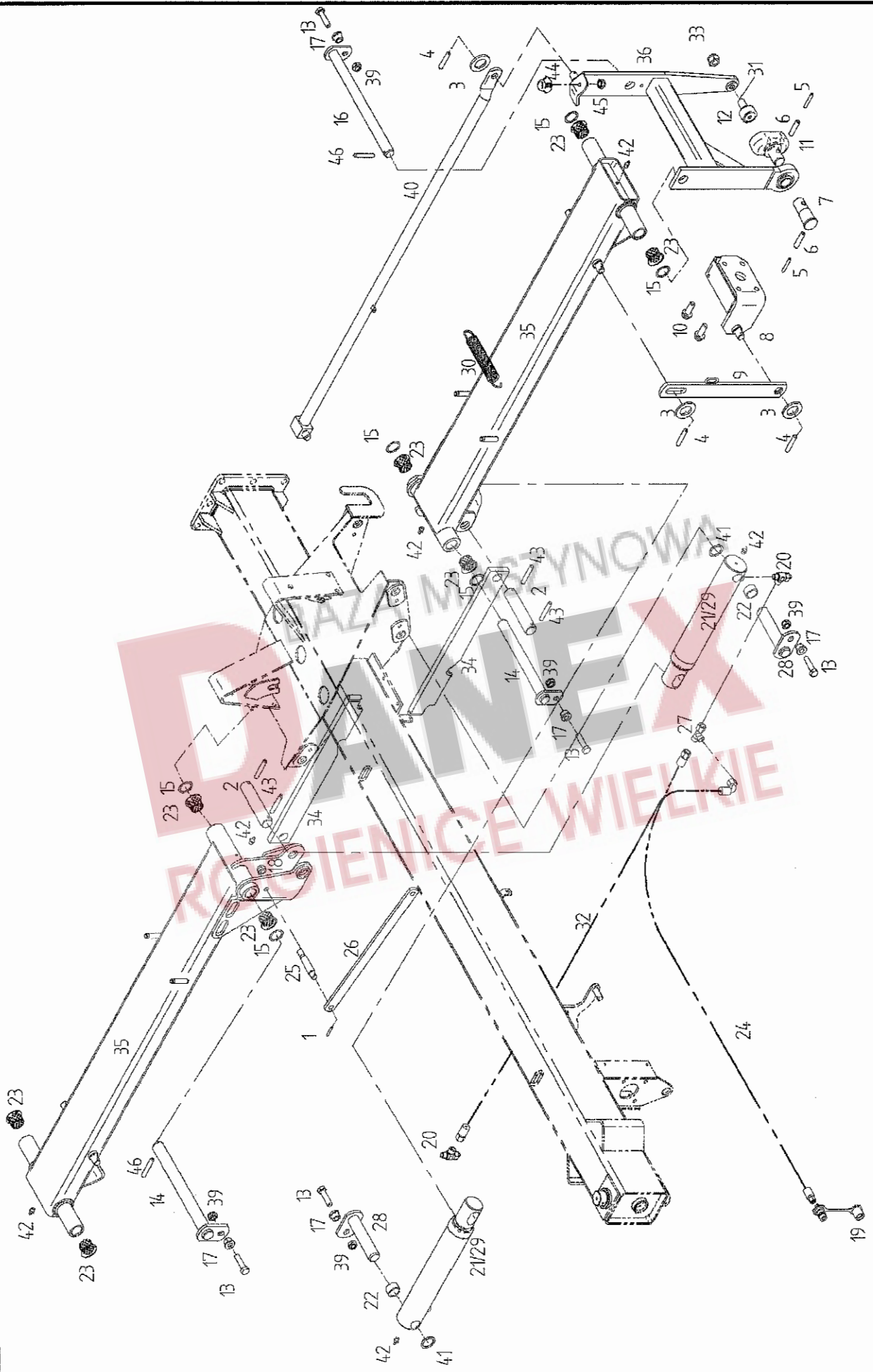

E00015 - 01		Schwenkarm		Swivel arm	
		ET =	Ersatzteil	Spare part	
		EV =	Verschleißteil	Wear part	
POS.	TeilNr	Status	Benennung	Description	ET-Tech-Daten
1	107451	ET	Spannstift	Tensioning pin	ISO 8752 6x36-A-St DAC
2	161049	ET	Scharnierachse	Hinge axle	
3	115989	ET	Scheibe	Washer	DIN 126 - 26 A0C
4	126880	ET	Spannstift	Tensioning pin	ISO 8752 8x45-A-St DAC
5	124702	ET	Spannstift	Tensioning pin	ISO 8752 8x55-A-St
6	127808	ET	Spannstift	Tensioning pin	ISO 8752 13x55-A-St
7	161149	ET	Bolzen	Pin	
8	162195	ET	Kreiselanschlag	Rotor stop	
9	161781	ET	Anschlaglasche	Stop bracket	
10	127987	ET	6kt-Schraube	Hexagonal bolt	M16x 40- 100 DAC Vpl Vri
11	162886	ET	Kulisse	Coulisse	
12	165150	ET	Kurvenrolle	Cam roller	
13	117772	ET	6kt-Schraube	Hexagonal bolt	DIN 933 M10x 40- 8.8 A0C
14	162250	ET	Achse	Axle	
15	120595	ET	Passscheibe	Adjusting washer	DIN 988 35x45x1
16	162249	ET	Achse	Axle	
17	162245	ET	Bundbuchse	Flange sleeve	
18	116699	ET	6kt-Mutter	Nut	DIN 985 M16- 8 A0C
19	126859	ET	SVK-Stecker	SVK plug	ISO 7241-12,5- 8L ST3- 8L A3C
20	123759	ET	Drossel-Ventil	Throttle valve	
21	163051	ET	Druckzylinder	Pressure cylinder	
22	161062	ET	Distanzbuchse	Distance bushing	
23	150530	ET	Bundbuchse	Flange sleeve	
24	161322	EV	Hydraulikschlauch	Hydraulic hose	
25	161077	ET	Bolzen	Pin	
26	161079	ET	Lasche	Tongue	
27	127980	ET	L-Verschraubung mit Dichtkegel	Screw fitting	
28	162257	ET	Achse	Axle	
29	162614	ET	Dichtungssatz	Set of seals	
30	163222	ET	Zugfeder	Pulling spring	
31	163645	ET	Kegelschmiernippel	Conical grease nipple	
32	163614	EV	Hydraulikschlauch	Hydraulic hose	
33	128190	ET	6kt-Mutter	Nut	DIN 985 M20x1.5- 8 A0C
34	164203	ET	Transportsicherung	Safety device for transport	
35	166114	ET	Schwenkarm	Swivel arm	
36	164325	ET	Kreiselaufhängung	Rotor suspension	
39	108441	ET	6kt-Mutter	Nut	DIN 985 M10- 8 A0C
40	163899	ET	Verstellstange	Adjusting bar	
41	126242	ET	Stützscheibe	Supporting plate	DIN 988 S 35x45x2.5
42	108292	ET	Kegelschmiernippel	Conical grease nipple	DIN 71412 A S8X1
43	127178	ET	Spannstift	Tensioning pin	ISO 8752 8x50-A-St DAC
44	151014	ET	Puffer	Bumper	
45	108441	ET	6kt-Mutter	Nut	DIN 985 M10- 8 A0C
46	107454	ET	Spannstift	Tensioning pin	ISO 8752 6x50-A-St DAC



E00016 - 01

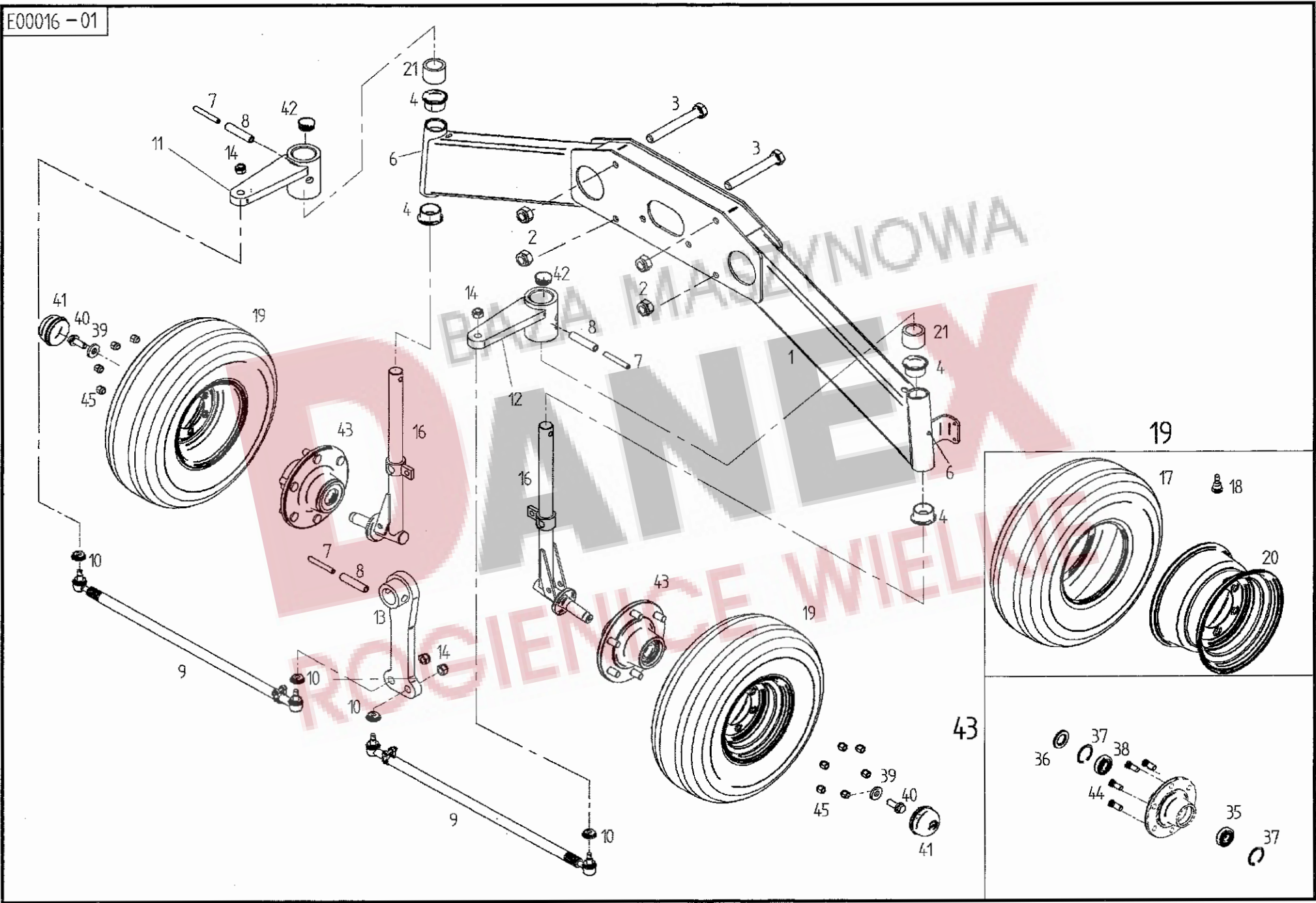

E00016 - 01		Fahrwerk, hinten		Chassis, back	
		ET =	Ersatzteil	Spare part	
		EV =	Verschleißteil	Wear part	
POS:	TeilNr	Status	Benennung	Description	ET-Tech-Daten
1	498501	ET	Rahmenquerträger	Traverse frame structure	
2	128190	ET	6kt-Mutter	Nut	DIN 985 M20x1.5- 8 A0C
3	128203	ET	6kt-Schraube	Hexagonal bolt	DIN 960 M20x1.5x150- 8.8 A0C
4	161098	ET	Bundbuchse	Flange sleeve	
6	108292	ET	Kegelschmiernippel	Conical grease nipple	DIN 71412 A S8X1
7	127973	ET	Spannstift	Tensioning pin	ISO 8752 10x75-A-St DAC
8	127972	ET	Spannstift	Tensioning pin	ISO 8752 16x75-A-St DAC
9	163945	ET	Spurstange	Track rod	
10	163352	ET	Dichtungsbalg mit Klemmring	Seal ring	
11	163942	ET	Spurhebel	Track lever	
12	163941	ET	Spurhebel	Track lever	
13	162672	ET	Lenkhebel	Steering lever	
14	128411	ET	6kt-Mutter	Nut	DIN 985 M14x1.5- 8 A0C
16	162427	ET	Achsschenkel	Steering knuckle	
17	128148	EV	Reifen	Tire	300/80-15.3 (11.5/80-15.3)
18	164363	EV	Gummiventil	Valve	DIN 7780 - 43GS16
19	132600	EV	Laufrad montiert	Track wheel mounted	300/80-15.3 (11.5/80-15.3)
20	122543	ET	Scheibenrad	Disc wheel	9.00x15.3
21	164674	ET	Buchse	Bushing	
35	127974	ET	Rillenkugellager	Grooved ball bearing	DIN 625 6307 2RS
36	108689	ET	Wellendichtring	Seal	DIN 3760 A 45x80x10
37	107386	ET	Sicherungsring	Snap ring	DIN 472 80x2.5
38	127770	ET	Rillenkugellager	Grooved ball bearing	DIN 625 6208 2RS
39	160756	ET	Scheibe	Washer	
40	127987	ET	6kt-Schraube	Hexagonal bolt	M16x 40- 100 DAC Vpl Vri
41	161883	ET	Abschlußkappe	Sealing hat	60 mm / 2.36 in
42	127961	ET	Lamellenstopfen	Lamellen plug	
43	133711	ET	Radnabe montiert	Wheel hub mounted	
44	108508	ET	Radbolzen	Wheel bold	M18x1,5 x 46
45	116700	ET	Kugelbundmutter	Spherical collar nut	DIN 74361 A18-8 A0C

E00018 -01

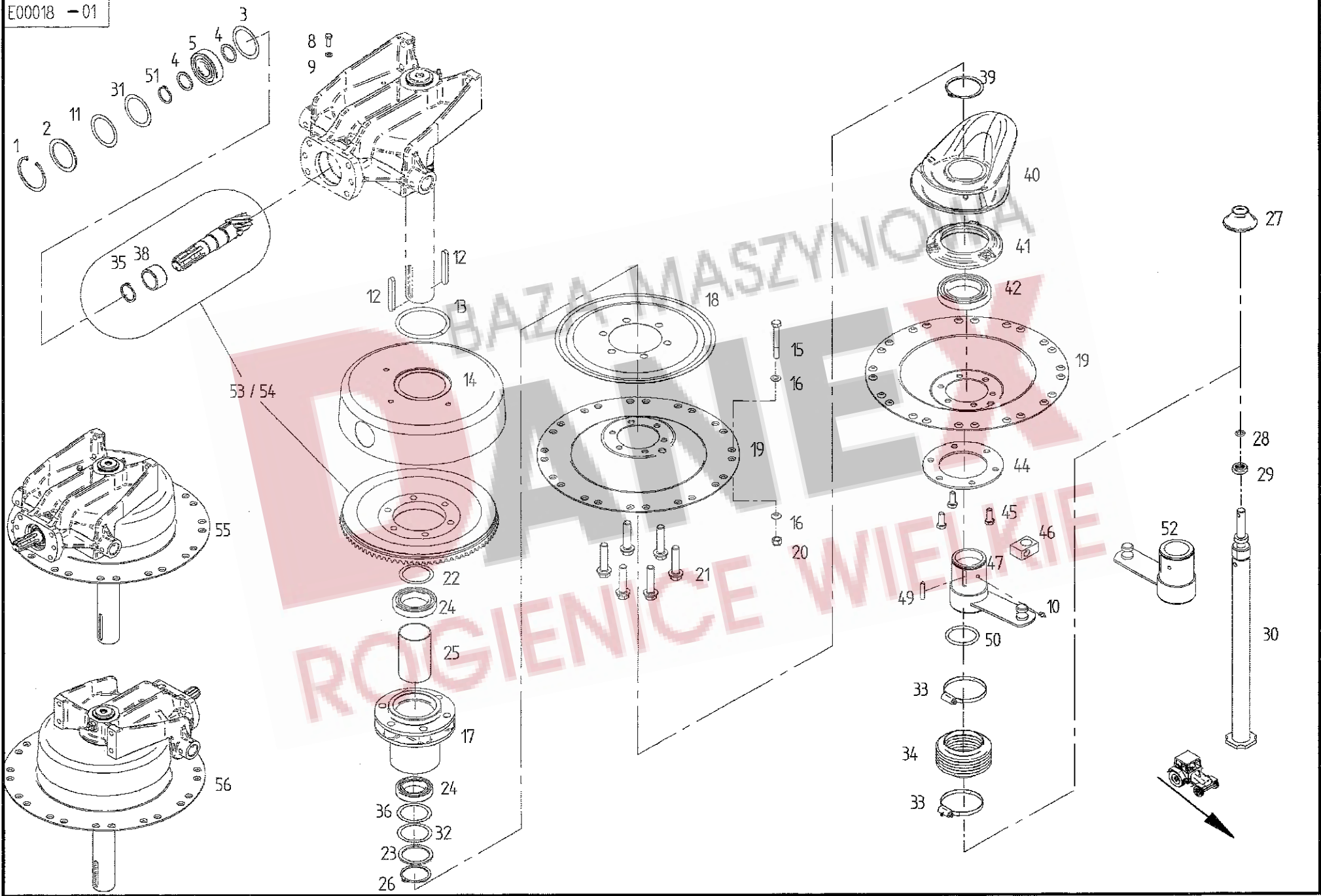

E00018 - 01		Kreiselkopf		Rotor head	
		ET =	Ersatzteil	Spare part	
		EV =	Verschleißteil	Wear part	
POS	TeilNr	Status	Benennung	Description	ET-Tech-Daten
1	107386	ET	Sicherungsring	Snap ring	DIN 472 80x2.5
2	127644	ET	Stützscheibe	Supporting plate	DIN 988 S 63x80x3
3	127645	ET	Passscheibe	Adjusting washer	DIN 988 63x80x0.3
4	126242	ET	Stützscheibe	Supporting plate	DIN 988 S 35x45x2.5
5	106852	ET	Rillenkugellager	Grooved ball bearing	DIN 625 6307 2RS C3
8	127883	ET	6kt-Schraube	Hexagonal bolt	DIN 933 M 8x 25- 8.8 A0C Vpl
9	115972	ET	Scheibe	Washer	DIN 125 - 8.4 A0C
10	108292	ET	Kegelschmiernippel	Conical grease nipple	DIN 71412 A S8X1
11	127646	ET	Passscheibe	Adjusting washer	DIN 988 63x80x0.5
12	127998	ET	Passfeder	Fitting spring	DIN 6885 A 12x8x90 C45K+V
13	160215	ET	Dichtring	Seal ring	
14	123477	ET	Haube	Cover	
15	128293	ET	6kt-Schraube	Hexagonal bolt	DIN 931 M12x 90-12.9 GEOM
16	163985	ET	Konusscheibe	Tapered nut washer	
17	162109	ET	Kreiselnabe	Rotor hub	
18	162111	ET	Deckel	Cover	
19	162112	ET	Glocke	Dome	
20	127564	ET	6kt-Mutter	Nut	DIN 982 M12-10 A0C
21	127988	ET	6kt-Schraube	Hexagonal bolt	M16x 70- 100 DAC Vpl Vri
22	124650	ET	Passscheibe	Adjusting washer	DIN 988 60x75x0.1
23	126302	ET	Stützscheibe	Supporting plate	DIN 988 S 60x75x3
24	118604	ET	Rillenkugellager	Grooved ball bearing	DIN 625 6012 2RS
25	123486	ET	Distanzrohr	Distance pipe	
26	127642	ET	Sicherungsring	Snap ring	DIN 471 60x3
27	160629	ET	Abdeckkappe	Cover hat	
28	126417	ET	O Ring	Ring	DIN 3771 17x3,55-N-NBR70
29	127416	ET	Axial-Rillenkugellager	Grooved ball thrust bearing	
30	161893	ET	Höhenverstellung	Height adjustment	
31	126320	ET	Passscheibe	Adjusting washer	DIN 988 63x80x0.1
32	126384	ET	Passscheibe	Adjusting washer	DIN 988 60x75x0.3
33	127768	ET	Schlauchschelle	Hose clip	DIN 3017 A-70- 90x 9-W4
34	121990	ET	Faltenbalg	Bellows	
35	127838	ET	Sicherungsring	Snap ring	DIN 471 40x2.5
36	126385	ET	Passscheibe	Adjusting washer	DIN 988 60x75x0.5
38	163061	ET	Innenring Nadelhülse	Inner ring	
39	105465	ET	Sicherungsring	Snap ring	DIN 471 75x2.5
40	163671	ET	Kurvenscheibe	Cam plate	
41	161543	ET	Lagerflansch	Bearing flange	
42	127640	ET	Rillenkugellager	Grooved ball bearing	DIN 625 6015 2RS
44	160135	ET	Ring	Ring	
45	127641	ET	6kt-Schraube	Hexagonal bolt	DIN 933 M12x 30- 8.8 A0C Vpl
46	123595	ET	Gelenkstück	Joint piece	
47	160141	ET	Nabe	Hub	
49	124506	ET	Passfeder	Fitting spring	DIN 6885 A 8x7x45 C45K+V
50	127638	ET	O Ring	Ring	DIN 3770 60x4-N-NBR70
51	118602	ET	Sicherungsring	Snap ring	DIN 471 35x2.5
52	160438	ET	Nabe	Hub	
53	163465	ET	Kegelradsatz	Set evel wheel	
54	162652	ET	Kegelradsatz	Set evel wheel	
55	498563	ET	Kreiselkopf	Rotor head	rotating clockwise
56	498564	ET	Kreiselkopf	Rotor head	rotating counter-clockwise

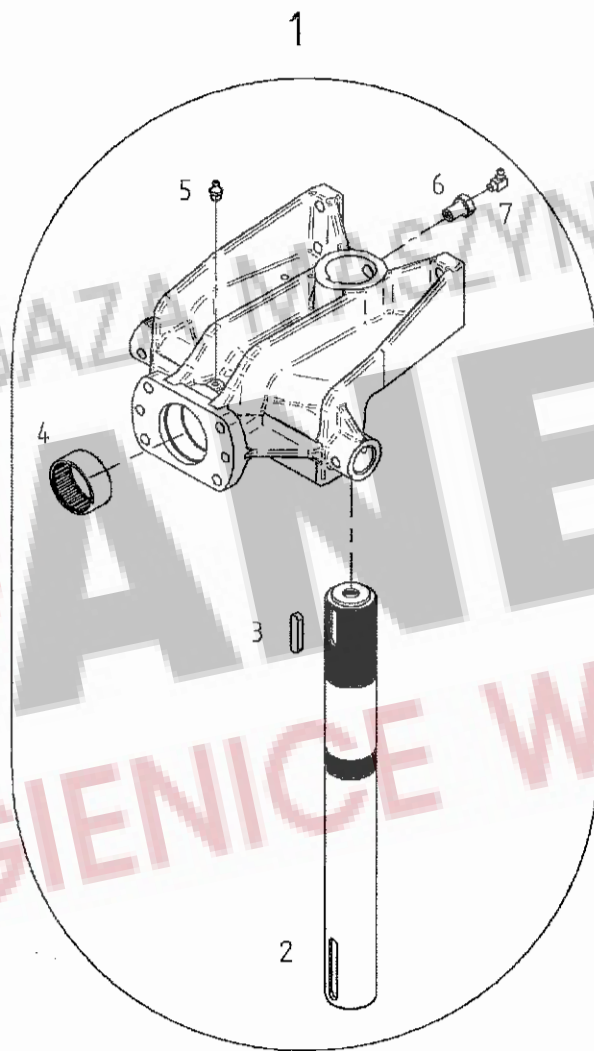

BAZAR PRACZYNOVA

**DAMEX**

ROGIENICE WIELKIE

<b>E00019 - 01</b>	<b>Kreiselkopf</b>	<b>Rotor head</b>
ET =	Ersatzteil	Spare part
EV =	Verschleißteil	Wear part

POS	TeilNr	Status	Benennung	Description	ET-Tech-Daten
1	498111	ET	Kreiselkopf	Rotor head	
2	161888	ET	Kreiselachse	Rotor axle	
3	108319	ET	Passfeder	Fitting spring	DIN 6885 A 12x8x56 C45K+V
4	127643	ET	Nadelhülse	Needle Bush	DIN 618 HK 5025
5	108292	ET	Kegelschmiernippel	Conical grease nipple	DIN 71412 A S8X1
6	160365	ET	Hohlschraube	Hollow bolt	M16x25
7	116749	ET	Kegelschmiernippel	Conical grease nipple	DIN 71412 C S8X1

BAZA MASZYNOWA  
**DANEX**  
 ROGIENICE WIELKIE

E00020-01

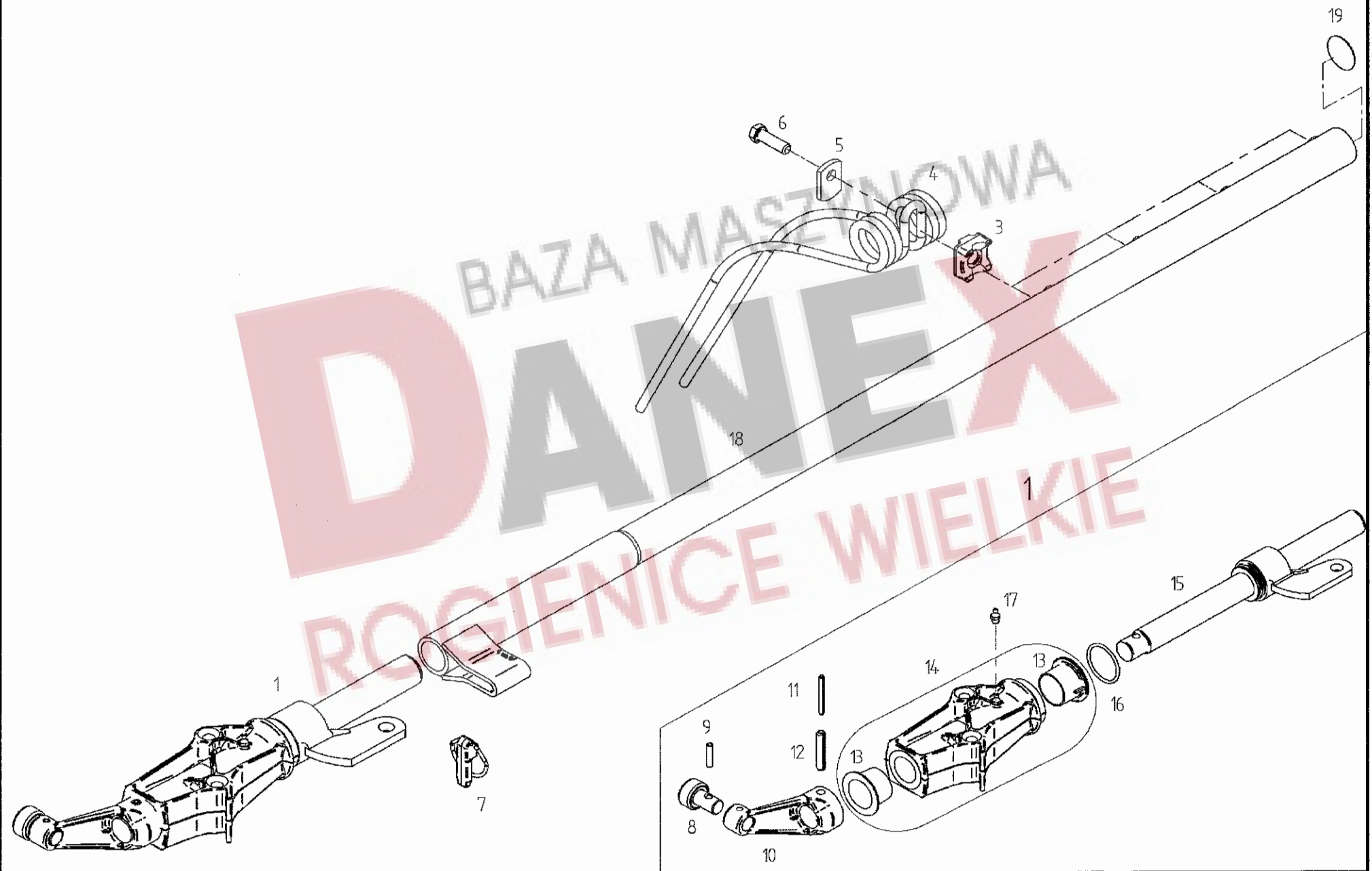

E00020 - 01		Zinkenträger	Tine arm		
	ET =	Ersatzteil	Spare part		
	EV =	Verschleißteil	Wear part		
POS	TeilNr	Status	Benennung	Description	ET-Tech-Daten
1	498522	ET	Kreiselarm	Rotor arm	
3	161379	ET	Klemmstück	Clamp	
4	160111	EV	Federzinken	Flexible tine	
5	160089	ET	Unterlage	Support	
6	126383	ET	6kt-Schraube	Hexagonal bolt	DIN 933 M12x 40-10.9 DAC
7	165162	ET	Klappstecker	Folding plug	
8	162071	ET	Laufrolle	Roller	
9	127607	ET	Spannstift	Tensioning pin	ISO 8752 7x32
10	162154	ET	Steuerhebel	Steering lever	
11	127253	ET	Spannstift	Tensioning pin	ISO 8752 6x55-A-St DAC
12	127252	ET	Spannstift	Tensioning pin	ISO 8752 10x55-A-St DAC
13	162153	ET	Bundbuchse	Flange sleeve	
14	498439	ET	Lagerrohr	Bearing tube	
15	163171	ET	Steuerwelle	Side shaft	
16	128103	ET	O Ring	Ring	DIN 3771 45x3,55-N-NBR90
17	108292	ET	Kegelschmiernippel	Conical grease nipple	DIN 71412 A S8X1
18	161631	ET	Zinkenträger	Tine arm	
19	128426	ET	Lamellenstopfen	Lamellen plug	



E00022-01

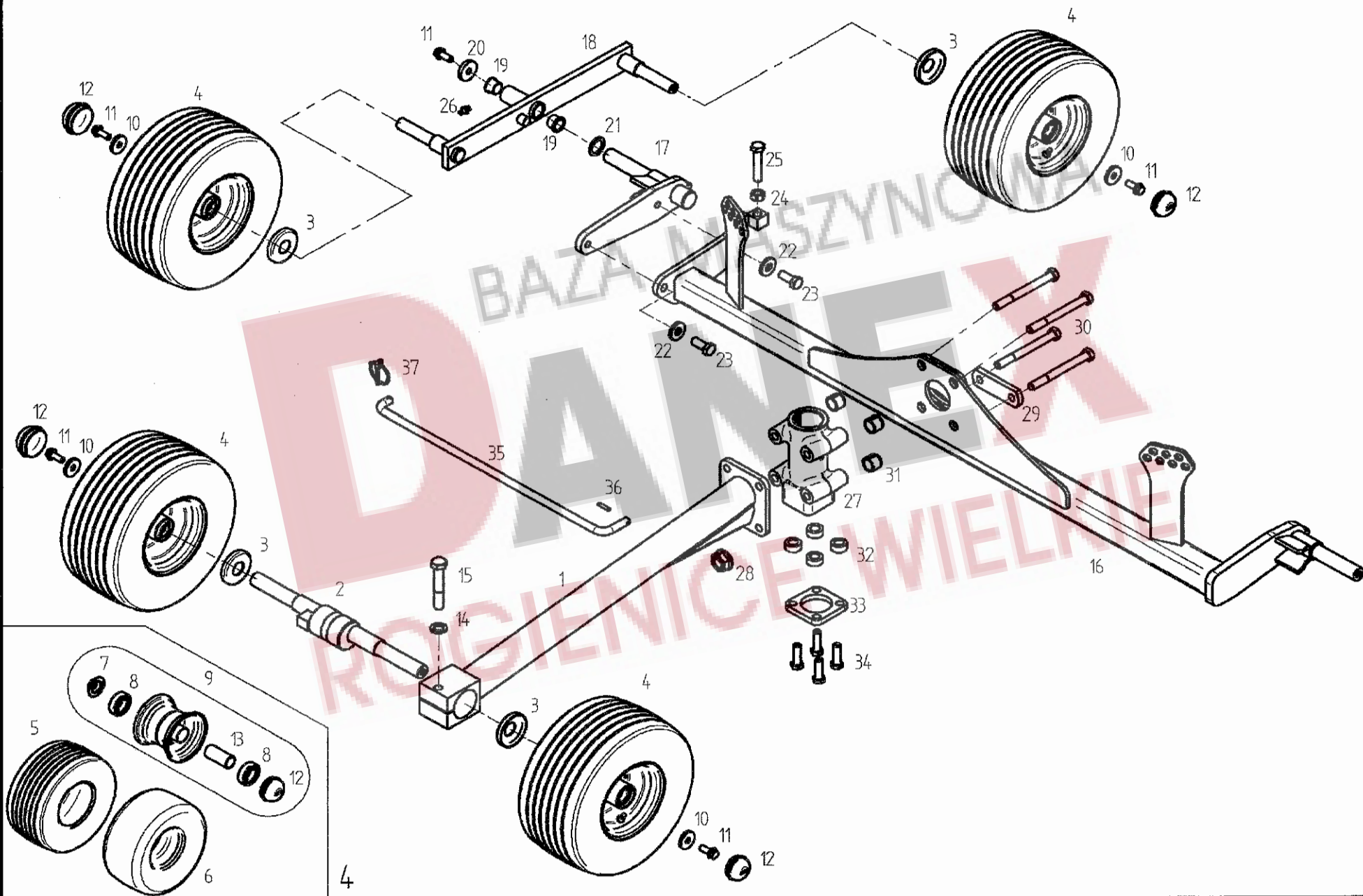

E00022 - 01		Achsen, Laufräder		Axle, track wheel	
	ET =	Ersatzteil		Spare part	
	EV =	Verschleißteil		Wear part	
POS	TeilNr	Status	Benennung	Description	ET-Tech-Daten
1	165871	ET	Achsausleger	Axle bracket	
2	165913	ET	Exzenterbolzen	Excentric bolt	
3	163864	ET	Schutzscheibe	Protective plate	
4	163809	EV	Laufrad montiert	Track wheel mounted	18x8.50-8 6PR
5	128059	EV	Reifen	Tire	18x8.50-8 6PR
6	128060	EV	Schlauch	Tube	18-18.5x8.50-8
7	163820	ET	Dichtring	Seal ring	
8	105327	ET	Rillenkugellager	Grooved ball bearing	DIN 625 6206 2RS
9	163810	ET	Tiefbettfelge	Drop base rim	7.00lx8
10	164333	ET	Scheibe	Washer	
11	135968	ET	6kt-Schraube	Hexagonal bolt	M12x 30- 100 DAC Vri Precote 5
12	126920	ET	Abschlußkappe	Sealing hat	62 mm / 2.44 in
13	163819	ET	Distanzrohr	Distance pipe	
14	116028	ET	Scheibe	Washer	DIN 1441 - 17 A0C
15	118546	ET	6kt-Schraube	Hexagonal bolt	DIN 931 M16x 90- 8.8 A0C
16	165872	ET	Achse	Axle	
17	165877	ET	Radträger	Wheel guide	
18	166232	ET	Tandemschwinge mit Buchsen	Tandem bracket with bushings	
19	150920	ET	Bundbuchse	Flange sleeve	
20	122886	ET	Scheibe	Washer	
21	124797	ET	Stützscheibe	Supporting plate	DIN 988 S 30x42x2.5
22	124517	ET	Scheibe	Washer	DIN 7349 - 17 A0C
23	109471	ET	6kt-Schraube	Hexagonal bolt	DIN 933 M16x 40- 8.8 A0C
24	116688	ET	6kt-Mutter	Nut	DIN 934 M16- 8 A0C
25	127608	ET	6kt-Schraube	Hexagonal bolt	DIN 933 M16x 80- 8.8 A0C
26	108292	ET	Kegelschmiernippel	Conical grease nipple	DIN 71412 A S8X1
27	165156	ET	Achsführung	Axle guide	
28	128708	ET	6kt-Mutter	Nut	M12-10 DAC Vri
29	161786	ET	Lasche	Tongue	
30	116484	ET	6kt-Schraube	Hexagonal bolt	DIN 931 M16x160- 8.8 A0C
31	128476	ET	Spannstift	Tensioning pin	DIN 7346 21x 16 DAC
32	161969	ET	Buchse	Bushing	
33	162159	ET	Flanschplatte	Flange plate	
34	126383	ET	6kt-Schraube	Hexagonal bolt	DIN 933 M12x 40-10.9 DAC
35	160120	ET	Stange	Rod	
36	107449	ET	Spannstift	Tensioning pin	ISO 8752 6x30-A-St DAC
37	124053	ET	Klappstecker	Folding plug	DIN 11023 6x42 ZN3

E00023-01

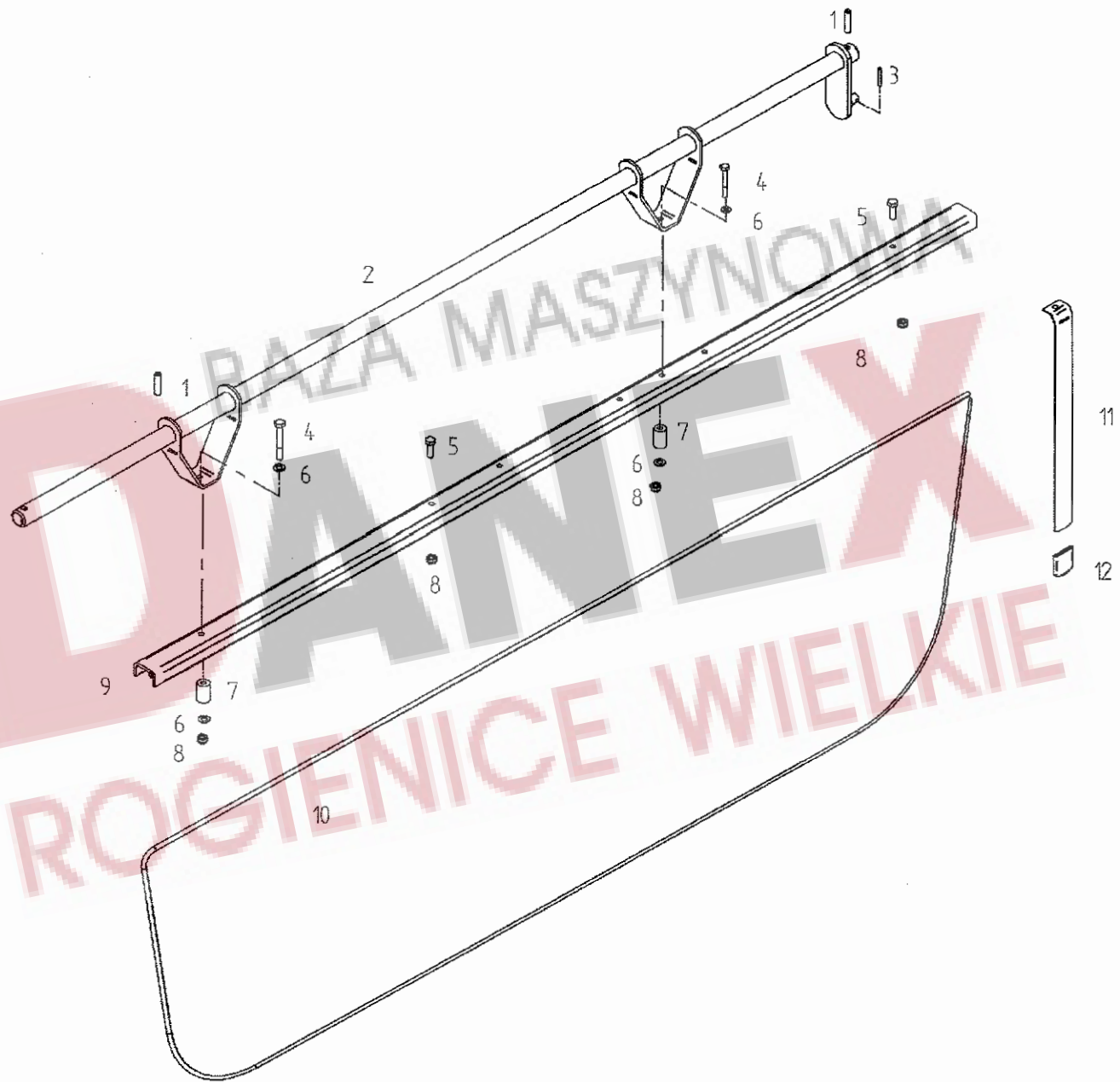

<b>E00023 - 01</b>	<b>Schwadformer</b>	<b>Swathformer</b>
	ET = Ersatzteil	Spare part
	EV = Verschleißteil	Wear part

POS	TeilNr	Status	Benennung	Description	ET-Tech-Daten
1	105464	ET	Spannstift	Tensioning pin	ISO 8752 10x45-A-St DAC
2	164178	ET	Führungsrohr	Guide tube	
3	107451	ET	Spannstift	Tensioning pin	ISO 8752 6x36-A-St DAC
4	127222	ET	6kt-Schraube	Hexagonal bolt	DIN 931 M 8x 60- 8.8 A0C
5	127569	ET	6kt-Schraube	Hexagonal bolt	DIN 933 M 8x 25- A2
6	115972	ET	Scheibe	Washer	DIN 125 - 8.4 A0C
7	160069	ET	Distanzbuchse	Distance bushing	
8	108531	ET	6kt-Mutter	Nut	DIN 985 M 8- 8 A0C
9	160536	ET	Schwadformerprofil	Profile of swathforming tool	
10	160537	EV	Schwadtuch	Cloth	
11	123609	ET	Flachfeder	Flat spring	
12	122103	ET	Schutzkappe	Protective cap	

BAZA MASZYNOWA  
**DANEX**  
 ROGIENICE WIELKIE

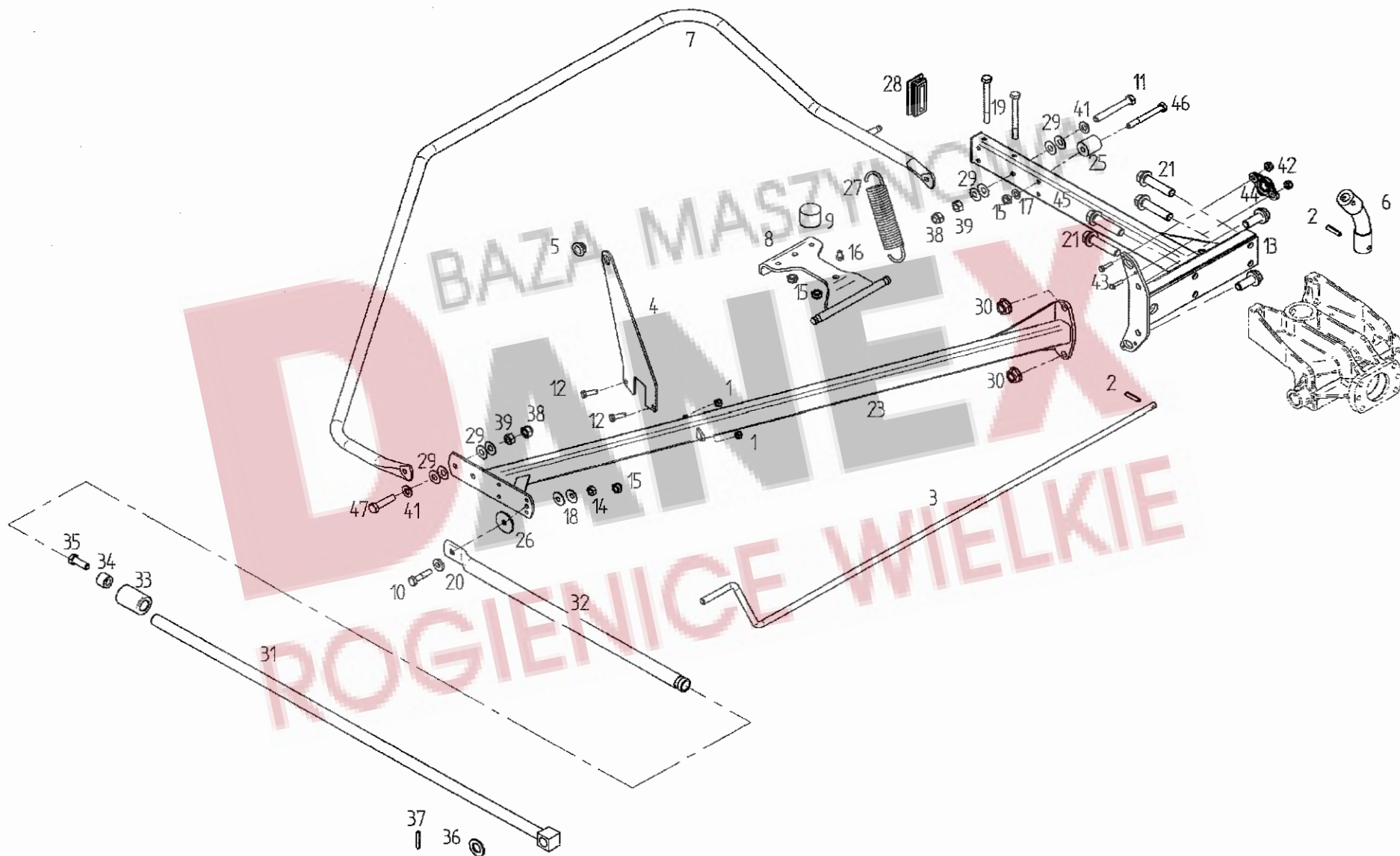

E00025 - 01		Schutzvorrichtung		Protective device	
		ET =	Ersatzteil	Spare part	
		EV =	Verschleißteil	Wear part	
POS	TeilNr	Status	Benennung	Description	ET-Tech-Daten
1	108531	ET	6kt-Mutter	Nut	DIN 985 M 8- 8 A0C
2	107464	ET	Spannstift	Tensioning pin	ISO 8752 8x36-A-St DAC
3	160214	ET	Kurbel	Crank	
4	165326	ET	Kurbelhalter	Crank holder	
5	162879	ET	Lagerbuchse	Bearing bush	
6	121970	ET	Biegsame Welle	Flexible shaft	
7	165810	ET	Schutzbogen	Arc-shaped guard	
8	165024	ET	Anschlag	Stop	
9	133810	ET	Gummipuffer	Rubber buffer	
10	116518	ET	6kt-Schraube	Hexagonal bolt	DIN 931 M10x 45- 8.8 A0C
11	128834	ET	6kt-Schraube	Hexagonal bolt	DIN 933 M12x 90- 8.8 A0C
12	116614	ET	6kt-Schraube	Hexagonal bolt	DIN 933 M 8x 25- 8.8 A0C
13	127987	ET	6kt-Schraube	Hexagonal bolt	M16x 40- 100 DAC Vpl Vri
14	116685	ET	6kt-Mutter	Nut	DIN 934 M10- 8 A0C
15	108441	ET	6kt-Mutter	Nut	DIN 985 M10- 8 A0C
16	116611	ET	6kt-Schraube	Hexagonal bolt	DIN 933 M 8x 12- 8.8 A0C Vpl
17	115973	ET	Scheibe	Washer	DIN 125 - 10.5 A0C
18	126825	ET	Tellerfeder	Disc spring	28x10.2x 1.5 MV8
19	116459	ET	6kt-Schraube	Hexagonal bolt	DIN 931 M10x100- 8.8 A0C
20	116118	ET	Scheibe	Washer	DIN 7349 - 10.5 A0C
21	127988	ET	6kt-Schraube	Hexagonal bolt	M16x 70- 100 DAC Vpl Vri
23	165325	ET	Schutzträger	Guard support	
25	165988	ET	Distanzbuchse	Distance bushing	
26	164341	ET	Kunststoffscheibe	Washer	
27	132982	ET	Zugfeder	Pulling spring	
28	128323	ET	Vierkantstopfen	Square plugscrew	
29	107096	ET	Tellerfeder	Disc spring	28x12.2x 1 MV8
30	128708	ET	6kt-Mutter	Nut	M12-10 DAC Vri
31	165804	ET	Stange	Rod	
32	165674	ET	Rohrstrebe	Tubular strut	
33	165765	ET	Führungsbuchse	Guide bushing	
34	163177	ET	Rolle	Roller	
35	128435	ET	6kt-Schraube	Hexagonal bolt	DIN 933 M12x 35- 8.8 A0C Vpl
36	108455	ET	Scheibe	Washer	DIN 125 - 21 A0C
37	107452	ET	Spannstift	Tensioning pin	ISO 8752 6x40-A-St DAC
38	127564	ET	6kt-Mutter	Nut	DIN 982 M12-10 A0C
39	116686	ET	6kt-Mutter	Nut	DIN 934 M12- 8 A0C
41	105186	ET	Scheibe	Washer	DIN 125 - 13 A0C
42	106903	ET	6kt-Mutter	Nut	DIN 985 M 6- 8 A0C
43	116609	ET	6kt-Schraube	Hexagonal bolt	DIN 933 M 6x 25- 8.8 A0C
44	163293	ET	Flanschlager	Flange bearing	
45	165320	ET	Konsole	Bracket	
46	109180	ET	6kt-Schraube	Hexagonal bolt	DIN 931 M10x 90- 8.8 A0C
47	116572	ET	6kt-Schraube	Hexagonal bolt	DIN 933 M12x 50- 8.8

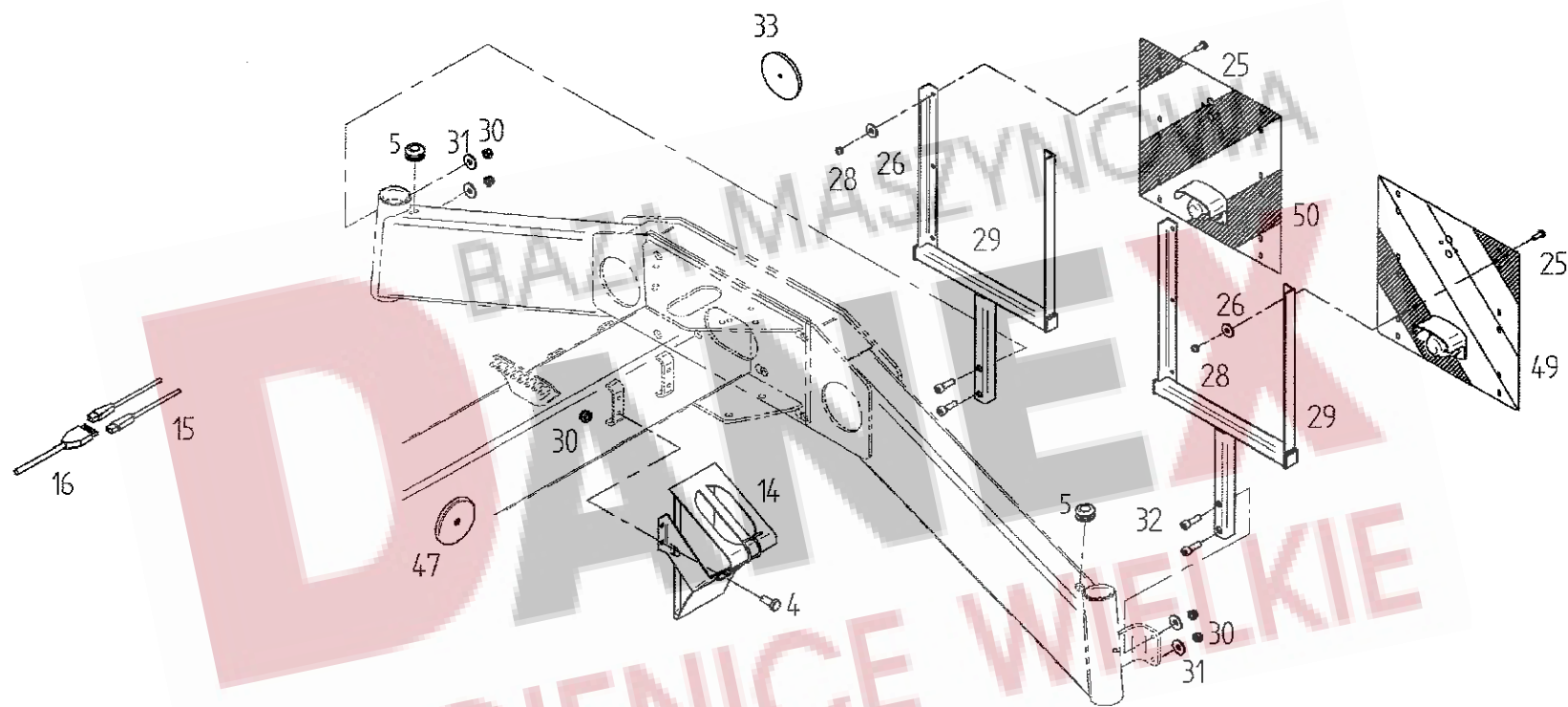

50

49

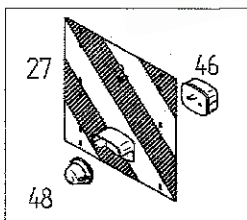
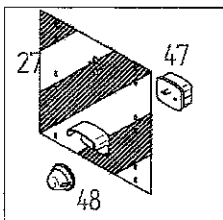

E00001 - 01		Beleuchtung		Illumination	
		ET =	Ersatzteil	Spare part	
		EV =	Verschleißteil	Wear part	
POS	TeilNr	Status	Benennung	Description	ET-Tech-Daten
4	107727	ET	6kt-Schraube	Hexagonal bolt	DIN 933 M 8x 20- 8.8 A0C
5	122471	ET	Gummidurchführung	Rubber bracket	
14	163372	ET	Unterlegkeil	Chock	
15	127725	ET	Reparatursetstecker	Repairing set plug	
16	161201	ET	Hauptkabel	Main cable	
25	116607	ET	6kt-Schraube	Hexagonal bolt	DIN 933 M 6x 16- 8.8 A0C
26	116030	ET	Scheibe	Washer	DIN 9021 - 7.4 A0C
27	150581	ET	Warntafel beidseitg	Warning sign support	
28	106903	ET	6kt-Mutter	Nut	DIN 985 M 6- 8 A0C
29	162314	ET	Warntafelhalter	Warning sign support	
30	108531	ET	6kt-Mutter	Nut	DIN 985 M 8- 8 A0C
31	105421	ET	Scheibe	Washer	DIN 9021 - 8.4 A0C
32	126752	ET	Zylinderschraube	Cheese head	DIN 912 M 8x 25- 8.8 A0C
33	127213	ET	Rückstrahler	Reflector	
46	162090	ET	Dreikammerleuchten	Three - unit lamp	
47	162091	ET	Dreikammerleuchten	Three - unit lamp	
47	128267	ET	Rückstrahler	Reflector	
48	162092	ET	Leuchte	Lamp	white
49	162315	ET	Warntafel mit Leuchte, links	Warning sign with light, left	
50	162316	ET	Warntafel mit Leuchte, rechts	Warning sign with light, right	



E00027 -01

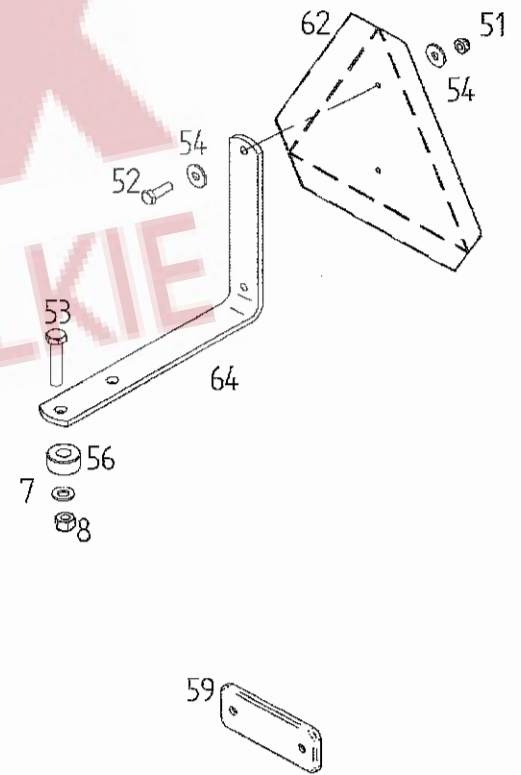
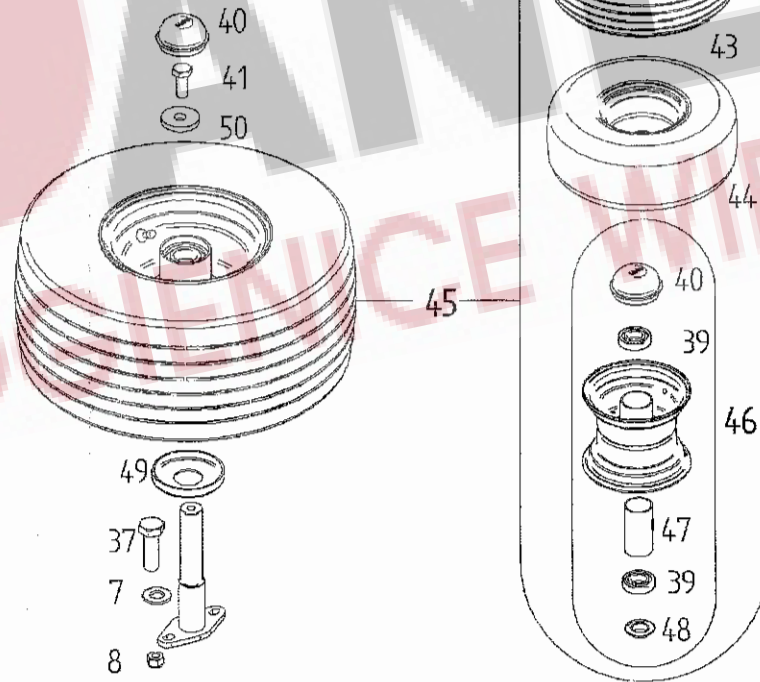
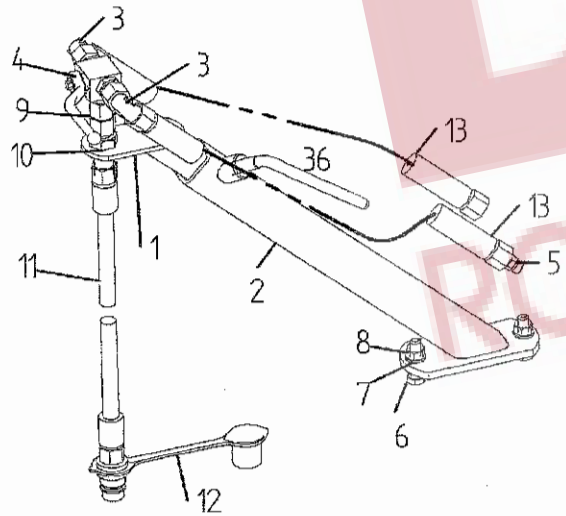
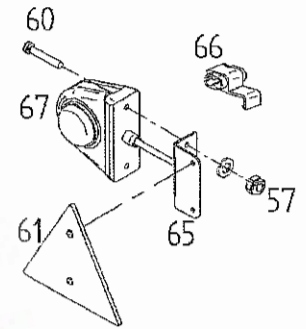
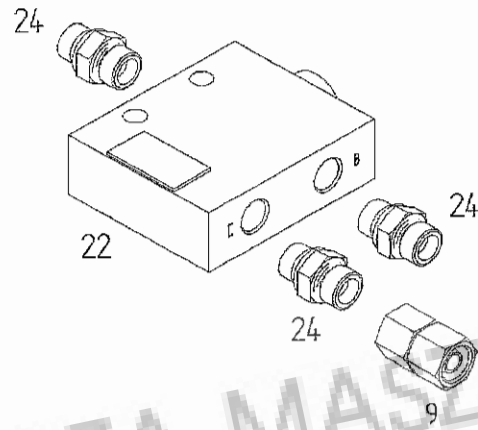
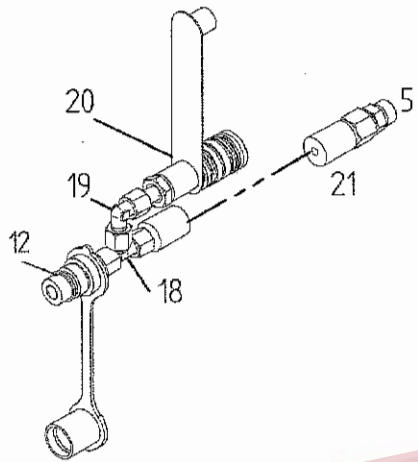

E00027-1		Sonderzubehör		Special equipment	
		ET =	Ersatzteil	Spare part	
		EV =	Verschleißteil	Wear part	
POS	TeilNr	Status	Benennung	Description	ET-Tech-Daten
1	162625	ET	Halter	Support	
2	164304	ET	Halter	Support	
3	127902	ET	W-Schwenkverschraubung	Swivelling screw fitting	
4	162603	ET	Dreiwege-Kugelhahn	Three way ball valve	
5	127950	ET	Verbindungsstück	Connection part	
6	117772	ET	6kt-Schraube	Hexagonal bolt	DIN 933 M10x 40- 8.8 A0C
7	115973	ET	Scheibe	Washer	DIN 125 - 10.5 A0C
8	127918	ET	6kt-Mutter	Nut	DIN 982 M10-10 A0C
9	128120	ET	Gerader Zwischenstutzen	Screw fitting.	GZ 10 S A3C
10	127978	ET	Gerade Schottverschraubung	Screw fitting	
11	162557	EV	Hydraulikschlauch	Hydraulic hose	
12	128070	ET	SVK-Stecker	SVK plug	ISO 7241-12,5-10S ST3-10S A3C
13	164326	EV	Hydraulikschlauch	Hydraulic hose	
18	127290	ET	Einstellbare L-Verschraubung	Adjustable screw fitting	
19	127476	ET	Einstellbare W-Verschraubung	Adjustable screw fitting	
20	127951	ET	SVK-Muffe	Socket	
21	161322	EV	Hydraulikschlauch	Hydraulic hose	
22	165700	ET	Stromteiler	Partition	
24	128170	ET	Gerade Verschraubung	Straight screw fitting	GE 10 S R A3C X
36	122292	ET	Druckknebel	Compression handle	
37	116623	ET	6kt-Schraube	Hexagonal bolt	DIN 933 M10x 35- 8.8 A0C
39	105327	ET	Rillenkugellager	Grooved ball bearing	DIN 625 6206 2RS
40	126920	ET	Abschlußkappe	Sealing hat	62 mm / 2.44 in
41	127641	ET	6kt-Schraube	Hexagonal bolt	DIN 933 M12x 30- 8.8 A0C Vpl
43	128059	EV	Reifen	Tire	18x8.50-8 6PR
44	128060	EV	Schlauch	Tube	18-18.5x8.50-8
45	163809	EV	Laufrad montiert	Track wheel mounted	18x8.50-8 6PR
46	163810	ET	Tiefbettfelge	Drop base rim	7.00lx8
47	163819	ET	Distanzrohr	Distance pipe	
48	163820	ET	Dichtring	Seal ring	
49	163864	ET	Schutzscheibe	Protective plate	
50	164333	ET	Scheibe	Washer	
51	106903	ET	6kt-Mutter	Nut	DIN 985 M 6- 8 A0C
52	116608	ET	6kt-Schraube	Hexagonal bolt	DIN 933 M 6x 20- 8.8 A0C
53	126871	ET	6kt-Schraube	Hexagonal bolt	DIN 933 M10x 50- 8.8 A0C
54	124512	ET	Scheibe	Washer	DIN 9021 - 6.4 A0C
56	122394	ET	Distanzstück	Distance piece	
57	128233	ET	6kt-Mutter	Nut	DIN 985 M 5- 5 A0C
59	126040	ET	Rückstrahler	Reflector	
60	128232	ET	Zylinderschraube	Cheese head	ISO 1207 M5x 30-4.8 A0C
61	151719	ET	Rückstrahler	Reflector	
62	137008	ET	Warntafel	Warning sign	
64	166105	ET	Halter	Support	
65	166109	ET	Haltewinkel	Retaining angle	
66	128829	ET	Kabelverbinder	Cable connector	
67	166143	ET	Begrenzungsleuchte	Limit lamp	

1 TS 880 PRO

2  **FELLA**

3  **FELLA**

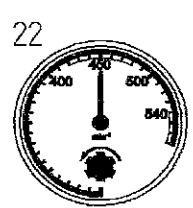
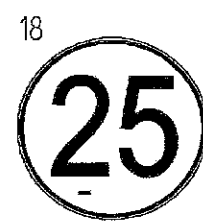
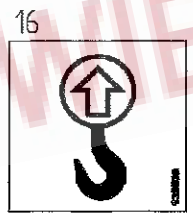
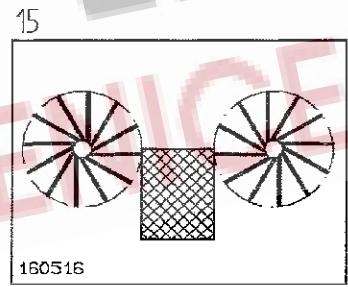
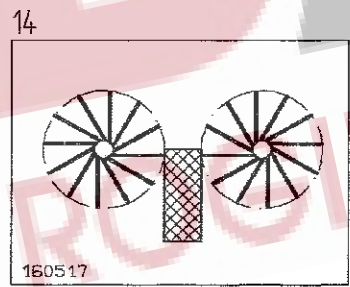
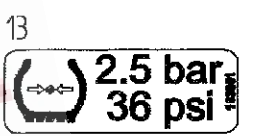
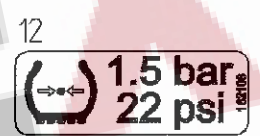
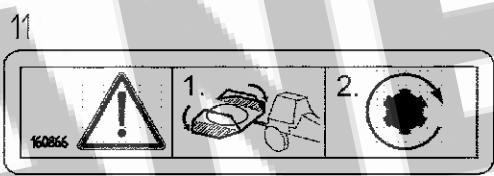
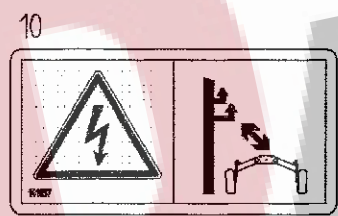
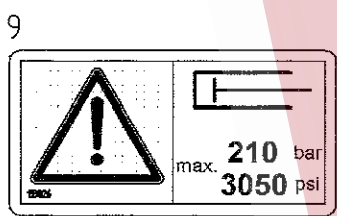
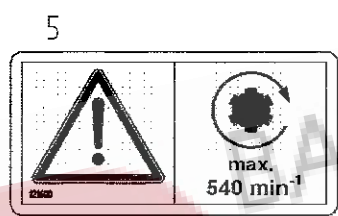
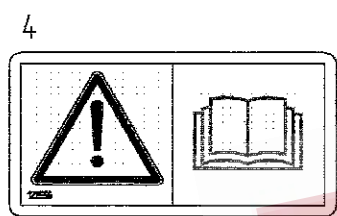

E00033-01		Aufkleber	Decal		
	ET =	Ersatzteil	Spare part		
	EV =	Verschleißteil	Wear part		
POS	TeilNr	Status	Benennung	Description	ET-Tech-Daten
1	166219	ET	Aufkleber	Decal	
2	122831	ET	Aufkleber	Decal	
3	122830	ET	Aufkleber	Decal	
4	122556	ET	Aufkleber	Decal	
5	121600	ET	Aufkleber	Decal	
6	121289	ET	Aufkleber	Decal	
7	150750	ET	Aufkleber	Decal	
8	161529	ET	Aufkleber	Decal	
9	133026	ET	Aufkleber	Decal	
10	141037	ET	Aufkleber	Decal	
11	160866	ET	Aufkleber	Decal	
12	162108	ET	Aufkleber	Decal	
13	163851	ET	Aufkleber	Decal	
14	160517	ET	Aufkleber	Decal	
15	160516	ET	Aufkleber	Decal	
16	132508	ET	Aufkleber	Decal	
17	163156	ET	Aufkleber	Decal	
18	133165	ET	Aufkleber	Decal	
19	133366	ET	Aufkleber	Decal	
20	133164	ET	Aufkleber	Decal	
21	165721	ET	Aufkleber	Decal	
22	165901	ET	Aufkleber	Lable	
23	128348	ET	Betriebsanleitung	Service instructions	

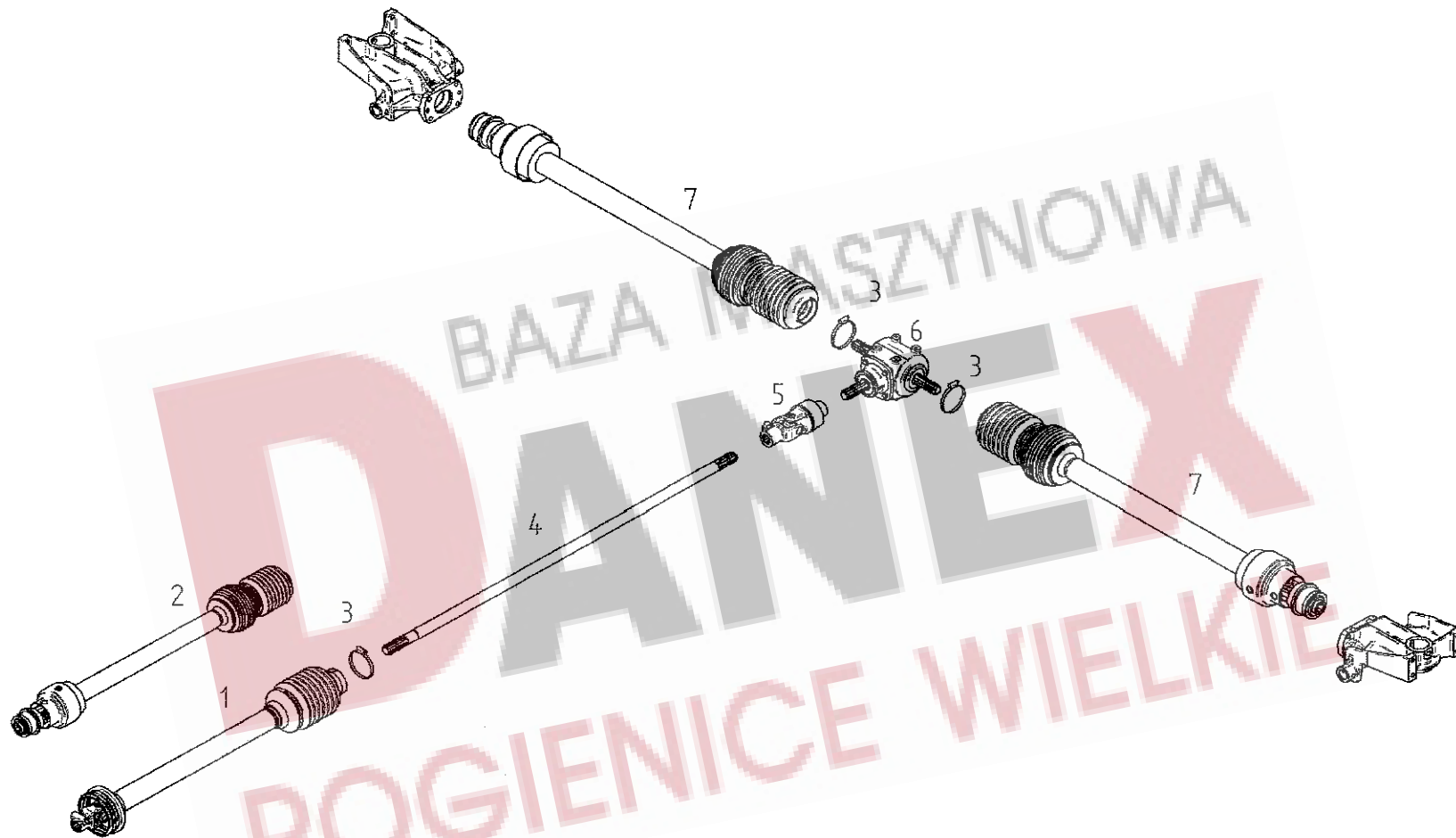

<b>E00031-01</b>	<b>Antriebsstrang</b>	<b>Driving gear</b>
ET =	Ersatzteil	Spare part
EV =	Verschleißteil	Wear part

POS	TeilNr	Status	Benennung	Description	ET-Tech-Daten
1	164661	ET	Gelenkwelle	PTO-shaft	
2	165946	ET	Weitwinkelgelenkwelle	Wide angel p.t.o. shaft	
3	128083	ET	Schlauchschelle	Hose clip	DIN 3017 A100-120x12-W1-2
4	165979	ET	Antriebswelle	Drive shaft	
5	165945	ET	Kreuzgelenk	Universal joint	
6	162386	ET	Getriebe	Gearbox	
7	163990	ET	Weitwinkelgelenkwelle	Wide angel p.t.o. shaft	

BAZA MASZYNOWA  
**DANEX**  
 ROGIENICE WIELKIE

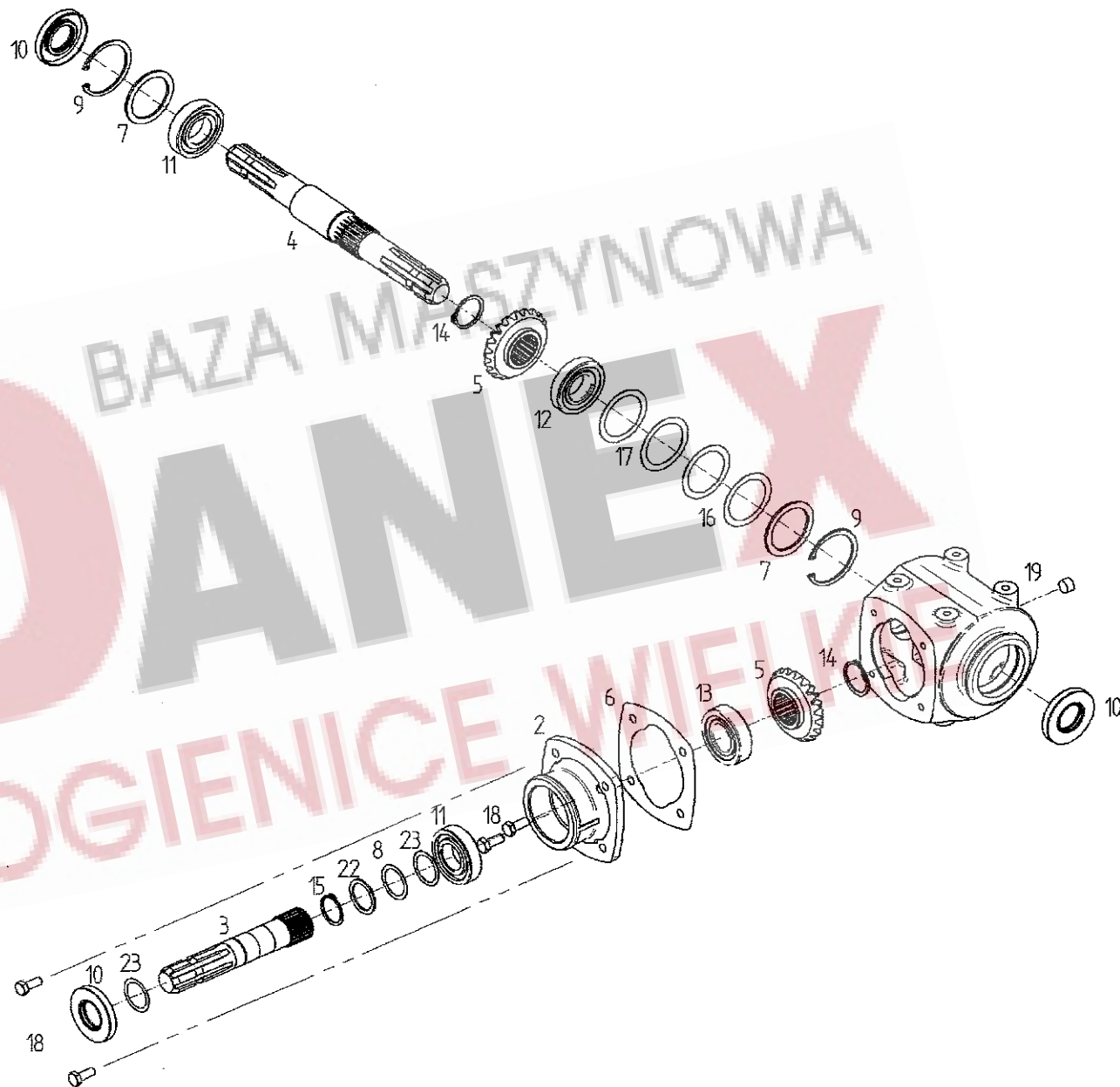

E00048-01		Getriebe GT30 1:1		Gearbox	
	ET =	Ersatzteil		Spare part	
	EV =	Verschleißteil		Wear part	
POS	TeilNr	Status	Benennung	Description	ET-Tech-Daten
0	162386	ET	Getriebe	Gearbox	
2	132149	ET	Gehäusedeckel	Housing cover	
3	132223	ET	Getriebewelle	Gear shaft	
4	132151	ET	Getriebewelle	Gear shaft	
5	132235	ET	Kegelrad	Bevel wheel	
6	132153	ET	Dichtung	Seal	
7	124151	ET	Stützscheibe	Supporting plate	DIN 988 S 56x72x3
8	126375	ET	Passscheibe	Adjusting washer	DIN 988 35x45x0.5
9	107385	ET	Sicherungsring	Snap ring	DIN 472 72x2.5
10	128096	ET	Wellendichtring	Seal	DIN 3760 AS 35x72x10
11	109525	ET	Rillenkugellager	Grooved ball bearing	DIN 625 6207
12	128098	ET	Kegelrollenlager	Tapped roller bearing	DIN 720 30207
13	128102	ET	Kegelrollenlager	Tapped roller bearing	DIN 720 32207
14	127789	ET	Sicherungsring	Snap ring	DIN 471 40x1.75 A0C
15	107367	ET	Sicherungsring	Snap ring	DIN 471 35x1.5
16	126368	ET	Passscheibe	Adjusting washer	DIN 988 56x72x0.3
17	126369	ET	Passscheibe	Adjusting washer	DIN 988 56x72x0.5
18	124508	ET	6kt-Schraube	Hexagonal bolt	DIN 933 M10x 25- 8.8 A0C Vpl
19	128092	ET	Verschlusschraube	Plug screw	DIN 906 M16x1.5 A0C
22	126376	ET	Passscheibe	Adjusting washer	DIN 988 35x45x2
23	124436	ET	Passscheibe	Adjusting washer	DIN 988 35x45x0.2



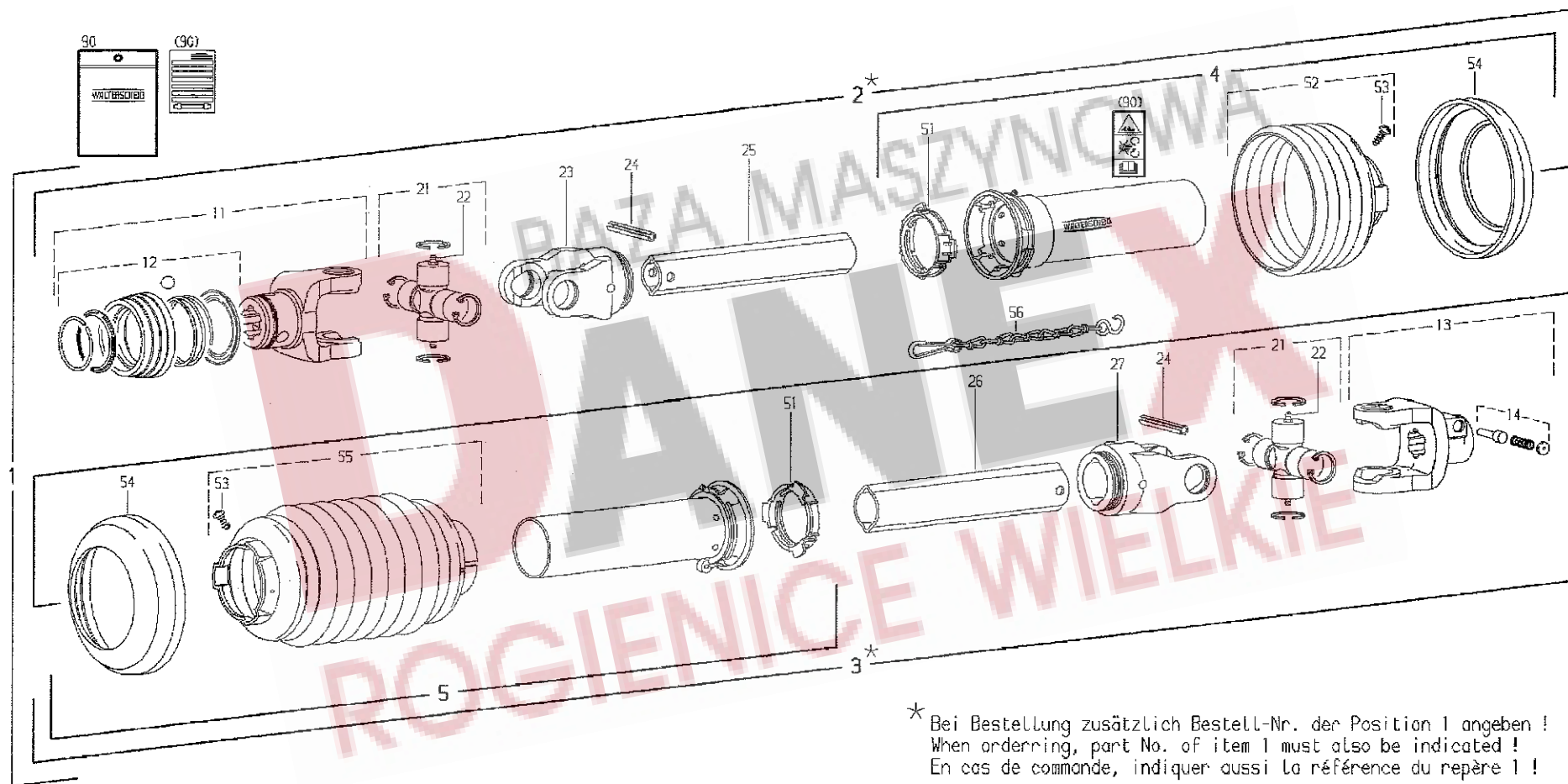

\* Bei Bestellung zusätzlich Bestell-Nr. der Position 1 angeben !  
 When ordering, part No. of item 1 must also be indicated !  
 En cas de commande, indiquer aussi la référence du repère 1 !

E00053-01		Gelenkwelle		PTO-Shaft	
		ET =	Ersatzteil	Spare part	
		EV =	Verschleißteil	Wear part	
POS	TeilNr	Status	Benennung	Description	ET-Tech-Daten
0	164661	ET	Gelenkwelle	PTO-shaft	W2300-SD15-860
2	102198		Innere Gelenkwellenhälfte	Inner PTO driveshaft half	
3	102199		Äußere Gelenkwellenhälfte	Outer PTO drive shaft half	
4	102193	ET	Äußere Schutzhälfte	Outer guard half	
5	102200	ET	Innere Schutzhälfte	Inner guard half	
11	102448	ET	Aufsteckgabel	Quick disconnect yoke	
12	102492	ET	ASE-Verschluß komplett	ASE-lock complete	
13	132553	ET	Aufsteckgabel	Quick disconnect yoke	
14	102066	ET	Schiebestift komplett	Quick disconnect pin cpl.	
21	102419	ET	Kreuzgarnitur kompl.	Cross and bearing kit cpl.	
22	102068	ET	Kegelschmiernippel	Conical grease nipple	AM6
23	102202	ET	Rillengabel	Inboard yoke	
24	102070	ET	Spannstift	Tensioning pin	ISO 8752 10x65
25	102203	ET	Profilrohr	Profile tube	
26	102204	ET	Profilrohr	Profile tube	
27	102205	ET	Rillengabel	Inboard yoke	
51	102076	ET	Gleitring	Bearing ring	
52	102306	ET	Schutztrichter	Guard cone	
53	102075	ET	Schraube	Screw	3.5x9.5
54	102102	ET	Stützring	Reinforcing collar	
55	102074	ET	Schutztrichter	Guard cone	
56	102101	ET	Haltekette	Safety chain	
90	102496	ET	Betriebsanleitung	Service instructions	

E00049 -01

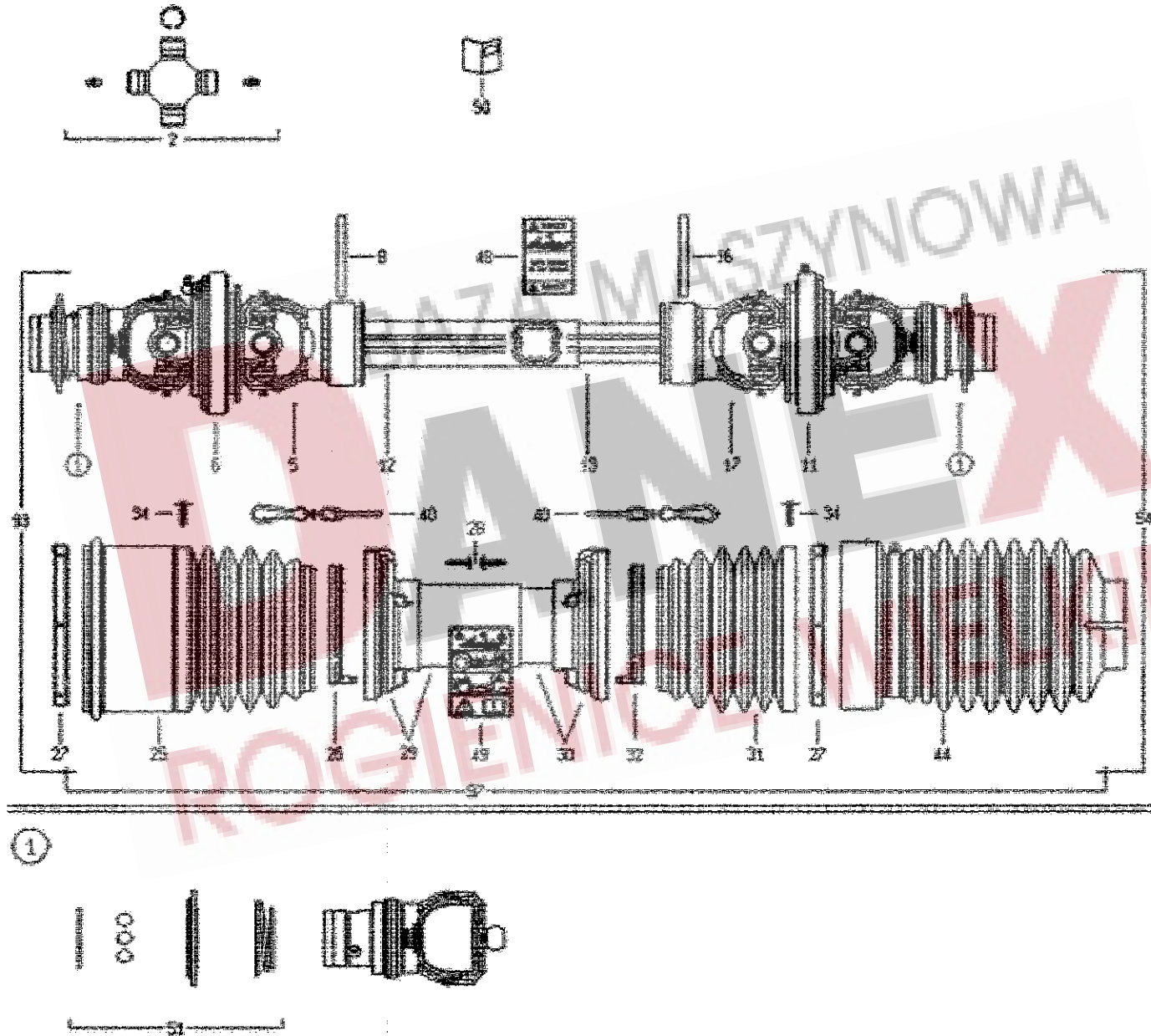

E00049-01		Gelenkwelle		PTO-Shaft		
		ET =	Ersatzteil	Spare part		
		EV =	Verschleißteil	Wear part		
POS	TeilNr	Status	Benennung	Description	ET-Tech-Daten	
0	165946	ET	Weitwinkelgelenkwelle	Wide angle p.t.o. shaft	DS4R076CEWR7W02/b	
1	102712	ET	Aufsteckgabel	Quick disconnect yoke		
2	102658	ET	Kreuzgarnitur kompl.	Cross and bearing kit cpl.	ISO 8752 8x80-A-St DAC	
5	102716	ET	Rillengabel	Inboard yoke		
6	102717	ET	Zentralgabel	Central yoke		
8	127579	ET	Spannstift	Tensioning pin		
11	102719	ET	Zentralgabel	Central yoke		
12	102472	ET	Profilrohr	Profile tube		
13	102471	ET	Profilrohr	Profile tube		
16	127579	ET	Spannstift	Tensioning pin		ISO 8752 8x80-A-St DAC
17	102718	ET	Rillengabel	Inboard yoke		
25	102700	ET	Schutztrichter	Guard cone		
26	102641	ET	Lauftring	Ring	BAZA MASZYNOWA <b>DANEX</b> ROGIENICE WIELKIE	
27	102661	ET	Lauftring	Ring		
28	102642	ET	Schraube	Screw		
29	102720	ET	Schutztrichter	Guard cone		
30	102721	ET	Schutztrichter	Guard cone		
31	102659	ET	Schutztrichter	Guard cone		
32	102643	ET	Lauftring	Ring		
34	102664	ET	Schraube	Screw		
40	102665	ET	Haltekette	Safety chain		
44	102722	ET	Schutztrichter	Guard cone		
48	102763	ET	Aufkleber	Label		
49	102764	ET	Aufkleber	Label		
51	102669	ET	Ziehverschluß komplett	Pull lock complete		

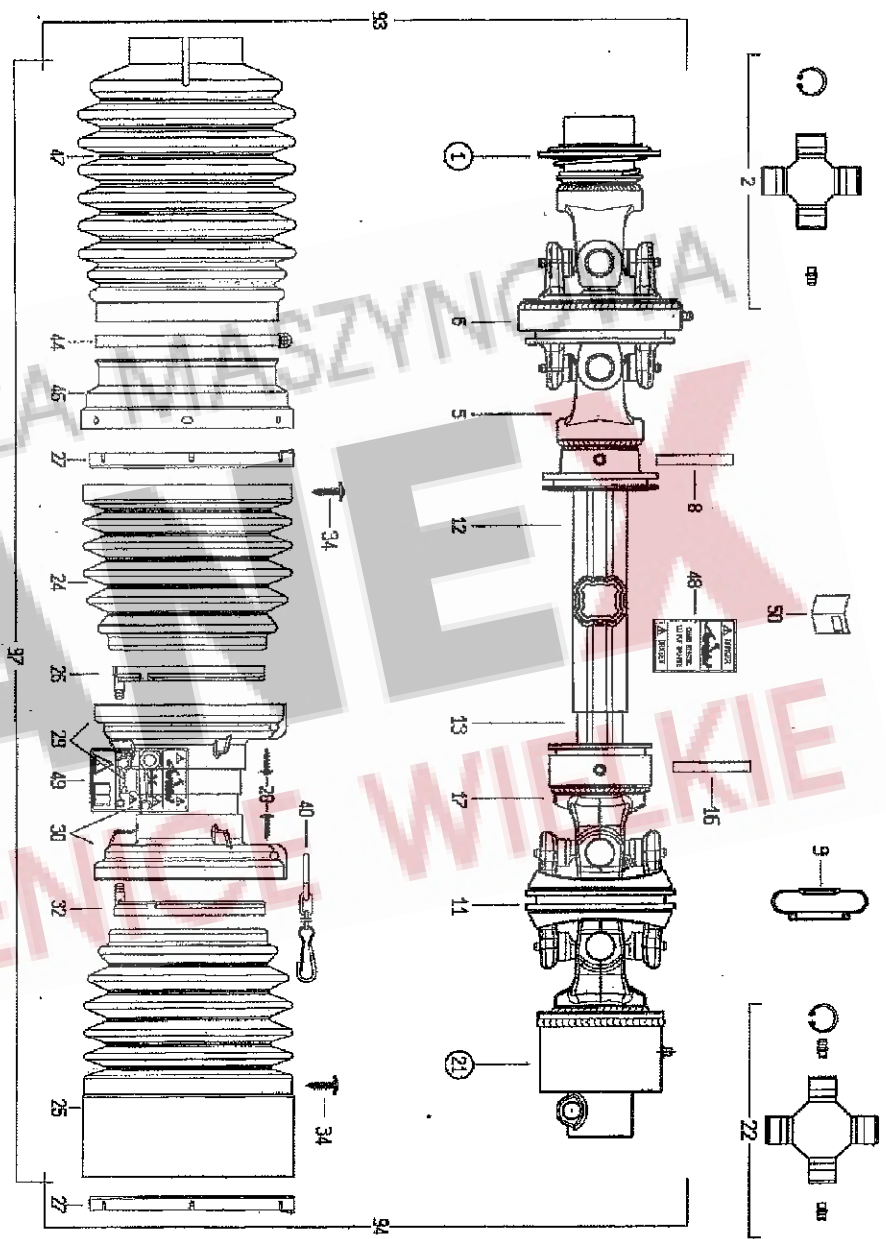
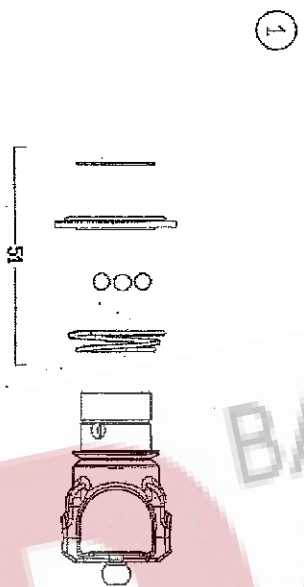
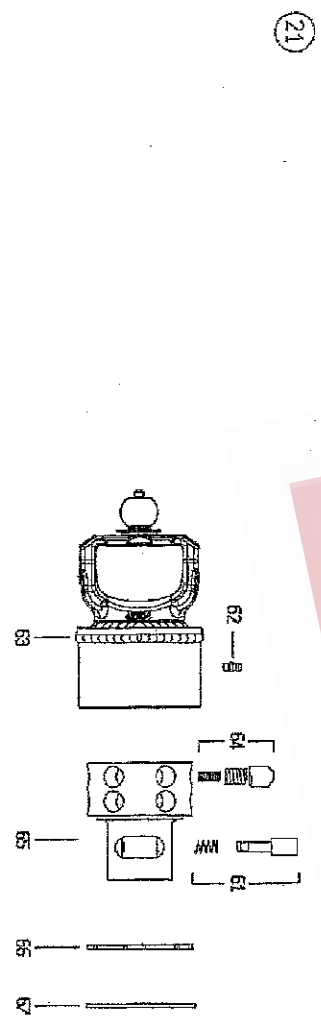

BAZA MASZYNOGRA  
ROGIENSKI WILKIE

E00054-01		Gelenkwelle		PTO-Shaft	
	ET =	Ersatzteil		Spare part	
	EV =	Verschleißteil		Wear part	
POS	TeilNr	Status	Benennung	Description	ET-Tech-Daten
0	163990	ET	Weitwinkelgelenkwelle	Wide angel p.t.o. shaft	DS2R101CEWR7K01
1	102140	ET	Aufsteckgabel	Quick disconnect yoke	
2	102650	ET	Kreuzgarnitur kompl.	Cross and bearing kit cpl.	
5	102651	ET	Rillengabel	Inboard yoke	
6	102652	ET	Zentralgabel	Central yoke	
8	107469	ET	Spannstift	Tensioning pin	ISO 8752 8x60-A-St DAC
9	102679	ET	Gummischeibe	Rubber washer	
11	102653	ET	Zentralgabel	Central yoke	
12	102654	ET	Profilrohr	Profile tube	
13	102655	ET	Profilrohr	Profile tube	
16	127579	ET	Spannstift	Tensioning pin	ISO 8752 8x80-A-St DAC
17	102656	ET	Rillengabel	Inboard yoke	
21	102657	ET	Sperrkörperkupplung	Stop device clutch	
22	102658	ET	Kreuzgarnitur kompl.	Cross and bearing kit cpl.	
24	102659	ET	Schutztrichter	Guard cone	
25	102660	ET	Schutztrichter	Guard cone	
26	102641	ET	Lauftring	Ring	
27	102661	ET	Lauftring	Ring	
28	102642	ET	Schraube	Screw	
29	102662	ET	Schutztrichter	Guard cone	
30	102663	ET	Schutztrichter	Guard cone	
32	102643	ET	Lauftring	Ring	
34	102664	ET	Schraube	Screw	
40	102665	ET	Haltekette	Safety chain	
44	128762	ET	Schlauchschelle	Hose clip	DIN 3017 A130-150x 9
46	102667	ET	Metallring	Ring	
47	102668	ET	Schutztrichter	Guard cone	
48	102763	ET	Aufkleber	Lable	
49	102764	ET	Aufkleber	Lable	
51	102669	ET	Ziehverschluß komplett	Pull lock complete	
61	102670	ET	Schiebestift komplett	Quick disconnect pin cpl.	
62	102671	ET	Schmiernippel	Rease nipple	
63	102672	ET	Kupplungsgehäuse	Coupling housing	
64	102673	ET	Sperrkörper mit Feder	Lock element with spring	
65	102674	ET	Aufstecknabe	Plug-in hub	
66	102675	ET	Abdeckring	Ring	
67	102676	ET	Sicherungsring	Snap ring	
93	102637	ET	Gelenkwellenhälfte außen	Outer PTO drive shaft half	



# Notizen / Notes / Notes



BAZA MASZYNOWA

DANEX

ROGIENICE WIELKIE







# Notizen/ Notes / Notes



BAZA MASZYNOWA  
**DANEX**  
ROGIENICE WIELKIE

**FELLA**

# Futterernte-Programm

**(D)**

Turbomäher  
Turbo-Scheibenmäher  
Turboheuer  
Turboschwader  
Großpackenpressen  
Rundballenpressen  
Ballenwickler

Technische Änderungen  
vorbehalten.

**(F)**

Turbofaucheuses à Tambours  
Turbofaucheuses à Disques  
Turbofaneurs  
Turboandaineurs  
Presse a balles cubiques  
Presse a balles rondes  
Enrubanneuses

Sous reserves de modifications  
techniques.

**(GB)**

Turbo-Drum-Mowers  
Turbo-Disc-Mowers  
Turbo-Tedders  
Turbo-Swather  
Big balers  
Round balers  
Wrappers

Subject to technical  
modifications.

**(NL)**

Trommelmaaiers  
Schijvenmaaiers  
Schudders  
Zwadharken  
Grootpakpersen  
Rondebalenpersen  
Balenwikkelaars

Technische veranderingen  
voorbehouden.

**(I)**

Turbo-Falciatrici a tamburi  
Turbo-Falciatrici a dischi  
Turbo-Spandi-Voltafieno  
Turbo-Ranghinatori  
Presse per balle gigante  
Roto pressa  
Fasciatore

Si fa riserva di modifiche tecniche.

**(E)**

Segadoras Turbo  
Segadoras a discos  
Turbo  
Henificadoras Turbo  
Hileradoras Turbo  
Empacadoras Cuadradas  
Rotoempacadoras  
Encintadoras

Nos reservamos el derecho de  
modificaciones técnicas.

**FELLA-Werke GmbH  
FELLA-Werke GmbH  
Telefax 00-49-9128/73-110**

**Zentraler Kundendienst:  
Zentrales Ersatzteillager:**

**Postfach 13 06  
Fellastraße 1-3  
Telefon 00-49-9128/73-0**

**Telefon 00-49-9128/73-229  
Telefon 00-49-9128/73-111**

**D-90533 Feucht  
D-90537 Feucht**

**E-Mail: [Service@fella.eu](mailto:Service@fella.eu)  
E-Mail: [ET@fella.eu](mailto:ET@fella.eu)**

**[www.fella.eu](http://www.fella.eu)**