

# FELLA Turboheuer

Ersatzteilliste  
Instructions de Service et Liste des Pièces de Rechange  
Operating Instructions and Spare Parts List  
Istruzioni sull'uso e distina delle parti di ricambio  
Gebruiksaanwijzing en Onderdeelenlist  
Bruksanvisning och Reservdelslista

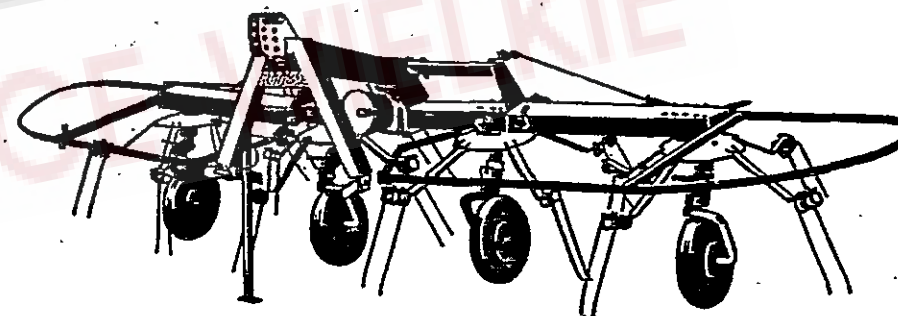

TH 410  
TH 410 D  
TH 520  
TH 520 D  
TH 700  
TH 700 D



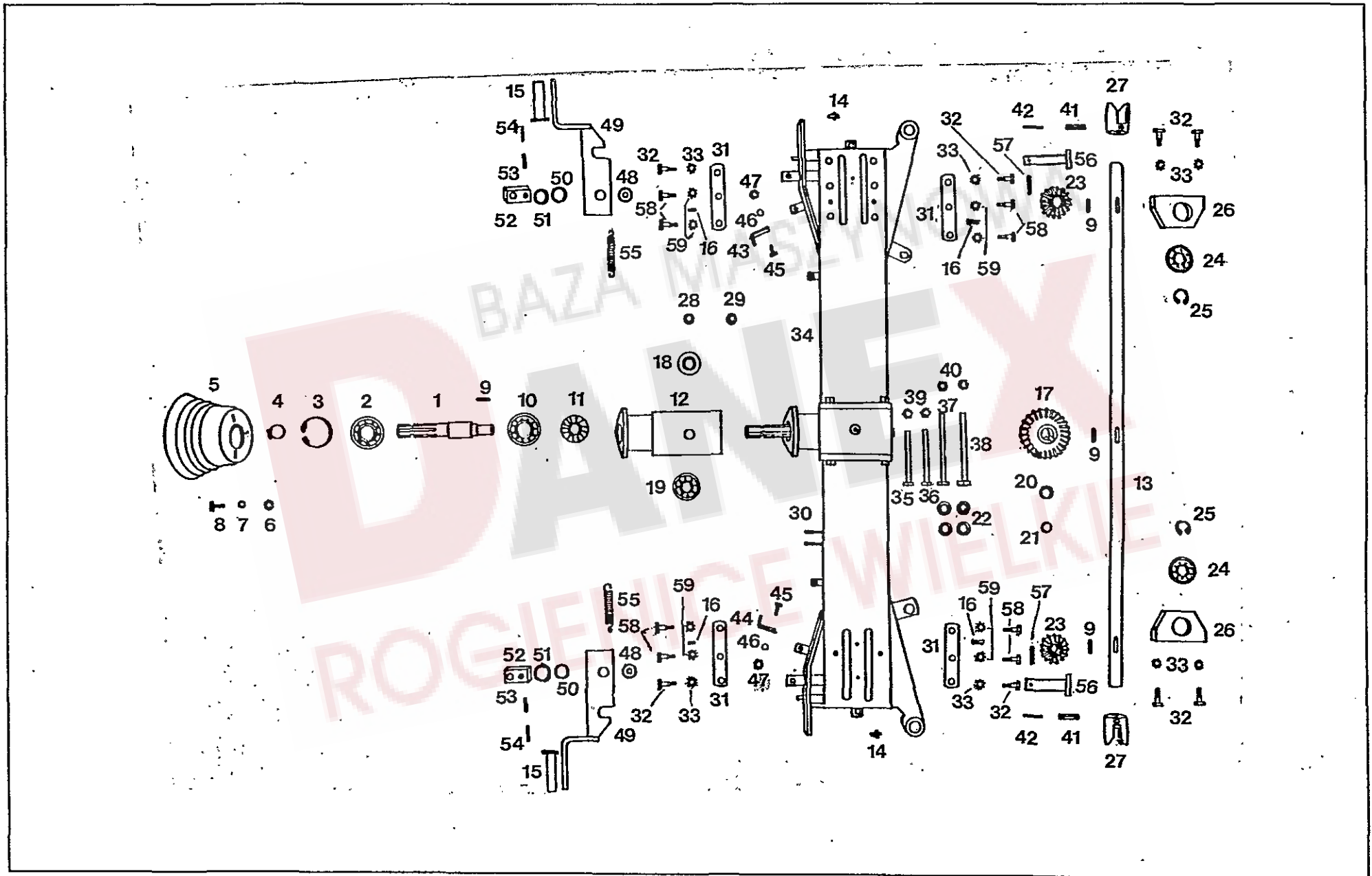

Pos.Nr. Pos.no. Rep. Pos. no.	Bezeichnung des Teiles Description of the part Désignation de la pièce Descrizione del pezzo		Nr. No. No. No.	TH430	TH430D	TH520	TH520D	TH700	TH700D
	RAHMEN, INNEN	FRAME, INSIDE	CHASSIS INTERIEUR						
1	Kurze Getriebewelle	Short p.t.o. shaft	Arbre d'entraînement court	486 071	x	x	x	x	x
2	Rillenkugellager 6207 2RS DIN625	Grooved ball bearing	Roulement rainuré à billes	124 758	x	x	x	x	x
3	Sicherungsring 72x2,5 DIN 472	Snap ring	Circlip intérieur	107 385	x	x	x	x	x
4	Sicherungsring 35x1,5 DIN 471	Snap ring	Circlip extérieur	107 367	x	x	x	x	x
5	Gelenkwellenschutz	P.t.o. guard	Protection pour l'arbre de transmission	486 050	x	x	x	x	x
6	Sicherungsmutter VM10DIN980-8 A1A	Retaining nut	Ecroude maintien	108 441	x	x	x	x	x
7	Scheibe 11 DIN 126 ZN3	Plate	Rondelle	115 983	x	x	x	x	x
8	6kt.-Schraube M10x25 DIN933-8.8 A1A	Hexagonal bolt	Vis à 6 pans	116 622	x	x	x	x	x
9	Paßfeder A 8x7x36 DIN 6885 vergütet	Fitting spring	Ressort de fixation	124 502	x	x	x	x	x
10	Rillenkugellager 6206 Z DIN 625	Grooved ball bearing	Roulement rainuré à billes	109 455	x	x	x	x	x
11	Kegelrad , klein Z=15	Bevel wheel	Pignon	461 106			x	x	x
	Kegelrad, klein Z=16	Bevel wheel	Pignon	486 181	x	x			
12	Hauptgetriebe	Main gear	Engrenage principal	487 473	x	x	x	x	x
13	Antriebswelle, innen	Inner p.t.o. shaft	Arbre d'entr. intérieur	487 955				x	x
	Antriebswelle, innen	Inner p.t.o. shaft	Arbre d'entr. intérieur	487 520			x		
	Antriebswelle, innen(ab Masch.Nr.2236)	Inner p.t.o.-shaft(as of machine No. 2236)	Arbre d'entr. intérieur(dès le no. de machine 2236)	487 818	x	x			
14	Kegelschmiernippel BM 8x1 DIN 71412	Conical grease nipple	Graisseur conique	116 746	x	x	x	x	x
15	Handgriff	Handle	Manette	111 216	x	x	x	x	x
16	Spannstift 8x30 DIN1481	Tension pin	Goupille	108 745	x	x	x	x	x
17	Großes Kegelrad Z=28	Big bevel wheel	Pignon grand	487 535			x	x	x
	Großes Kegelrad Z=27	Big bevel wheel	Pignon grand	487 534	x	x			
18	Radialdichtring AS30x62x7 DIN 3760	Radial seal	Bague	107 047	x	x	x	x	x
19	Rillenkugellager 6206-2RSDIN625	Grooved ball bearing	Roulement rainuré à billes	124 757	x	x	x	x	x
20	Distanzbuchse	Distance bysh	Douille à distance	486 061	x	x	x	x	x
21	Distanzscheibe, nach Bedarf	Distance plate, upon request	Plaque à distance, selon besoin	455 777	x	x	x	x	x
22	Spannstift 18x24 DIN 7346	Tension pin	Goupille	124 289	x	x	x	x	x
23	Kleines Kegelrad	Small bevel wheel	Pignon petit	487 203	x	x	x	x	x
24	Rillenkugellager 6206-2RS DIN 625	Grooved ball bearing	Roulement rainuré à billes	124 757	x	x	x	x	x
25	Sicherungsring 62x2DIN472	Snap ring	Circlip intérieur	107 383	x	x	x	x	x
26	Lagerbock	Bearing bracket	Support de palier	487 548	x	x	x	x	x
27	Kupplung	Clutch	Couplage	488 221	x	x	x	x	x
28	verschlußschraube M24x1,5DIN 909-6	Plug screw	Bouchon fileté	107 104	x	x	x	x	x
29	Entlüftungsverschlußschr.M24x1,5DIN909-6	Plug screw for air escape	Bouillon fileté pour aération	477 656	x	x	x	x	x
30	Rahmen,links, innen	Frame, inside,left side	Châssis, gauche, intérieur	487 988G				x	x
	Rahmen,links,innen	Frame, inside, left side	Châssis, gauche, intérieur	487 404G	x	x			
	Rahmen,links,innen	Frame, inside, left side	Châssis, gauche,intérieur	487 536G			x		
	Fortsetzung nächste Seite	Continued on next page	Continué sur la page suivante						

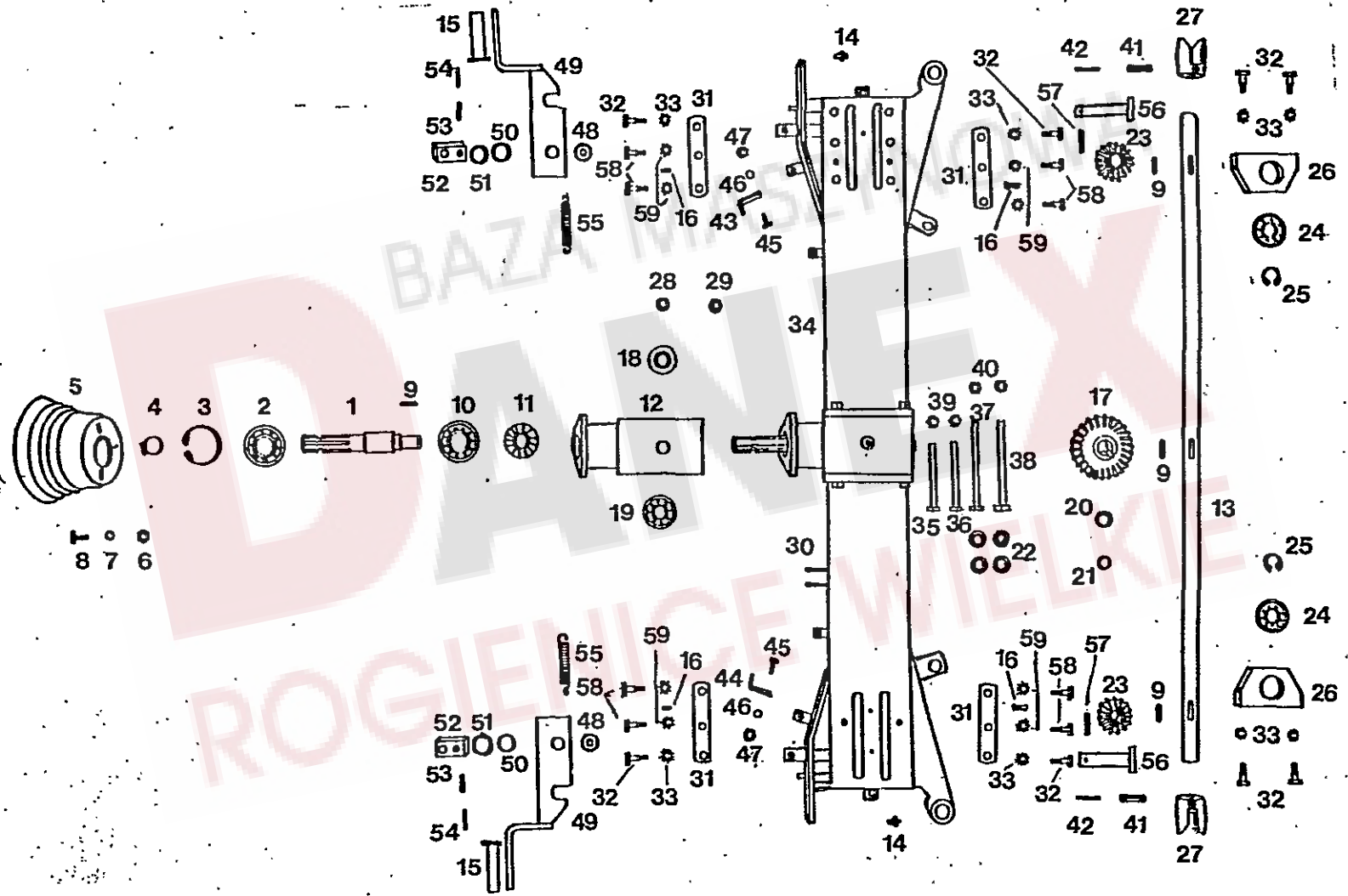

## Ersatzteilliste

## Tafel, Table, Plan, Tav.

1

Pos.Nr. Pos.no. Rep. Pos.no.	Bezeichnung des Teiles Description of the part Désignation de la pièce Descrizione del pezzo	As of machine-No. Dès le No de machine	* ab Masch.Nr. 5987 ** ab Masch.Nr. 7712 *** ab Masch.Nr. 536	Nr. No. No. No.	*	*	**	**	***	***
31	Verstärkungsleiste	Reinforcement plate		487 760	x	x	x	x	x	x
32	Paßschraube M 12x40 DIN7968-8.8	Screw		118 440	x	x	x	x	x	x
33	Zahnscheibe 13,2DIN 6797-ZN3	Toothed plate		105 524	x	x	x	x	x	x
34	Rahmen, rechts, innen	Inner frame; right side		487 987G					x	x
	Rahmen, rechts, innen	Inner frame, right side		487 403G	x	x				
	Rahmen, rechts, innen	Inner frame, right side		487 537G						
35	6kt.-Schraube M16x180 DIN931-8.8	Hexagonal bolt		116 486	x	x	x	x	x	x
36	6kt.-Schraube M16x160 DIN931-8.8	Hexagonal bolt		116 484	x	x	x	x	x	x
37	6kt.-Schraube M14x180 DIN931-8.8	Hexagonal bolt		124 268	x	x	x	x	x	x
38	6kt.-Schraube M14x160 DIN931-8.8	Hexagonal bolt		116 477	x	x	x	x	x	x
39	Sicherungsmutter VM 16DIN 980-8 A1A	Retaining nut		116 699	x	x	x	x	x	x
40	Sicherungsmutter VM 14 DIN 980-8 A1A	Retaining nut		109 363	x	x	x	x	x	x
41	Spannstift 12x50 DIN1481	Tension pin		107 478	x	x	x	x	x	x
42	Spannstift 7x50 DIN1481	Tension pin		105 463	x	x	x	x	x	x
43	Halter, rechts	Support, right side		487 970	x	x	x	x	x	x
44	Halter, links	Support, left side		487 971	x	x	x	x	x	x
45	6kt.-Schraube M8x25 DIN 933-8.8A1A	Hexagonal bolt		116 614	x	x	x	x	x	x
46	Tellerfeder 16x8,2x0,9 DIN 2093	Spring		108 611	x	x	x	x	x	x
47	Sicherungsmutter VM 8DIN980-8 A1A	Retaining nut		108 531	x	x	x	x	x	x
48	Innenring LR25x30x12,5	Inner ring		124 939					x	x
49	Riegel, geschw.	Lock, welded		487 975G					x	x
	Riegel, geschw.	Lock, welded		487 547G						
50	Scheibe nach Bedarf	Washer		463 078	x	x	x	x	x	x
51	Scheibe	Washer		223 679	x	x	x	x	x	x
52	Halter	Support		487 401	x	x	x	x	x	x
53	Spannstift 10x36 DIN1481	Tension pin		124 269	x	x	x	x	x	x
54	Spannstift 6x36 DIN1481	Tension pin		107 451	x	x	x	x	x	x
55	Zugfeder (352 294)	Pulling spring		110 860	x	x	x	x	x	x
56	Bolzen, geschw.	Bolt, welded		487 000G					x	x
	Bolzen, geschw.	Bolt, welded		487 553G	x	x	x	x		
57	Spannstift 8x40DIN1481	Tension pin		107 465	x	x	x	x	x	x
58	6kt.-Schraube M12x25DIN 933-8.8A1A	Hexagonal bolt		107 738	x	x	x	x	x	x
59	Zahnscheibe A 12,5 DIN6797-ZN3	Washer		116 051	x	x	x	x	x	x

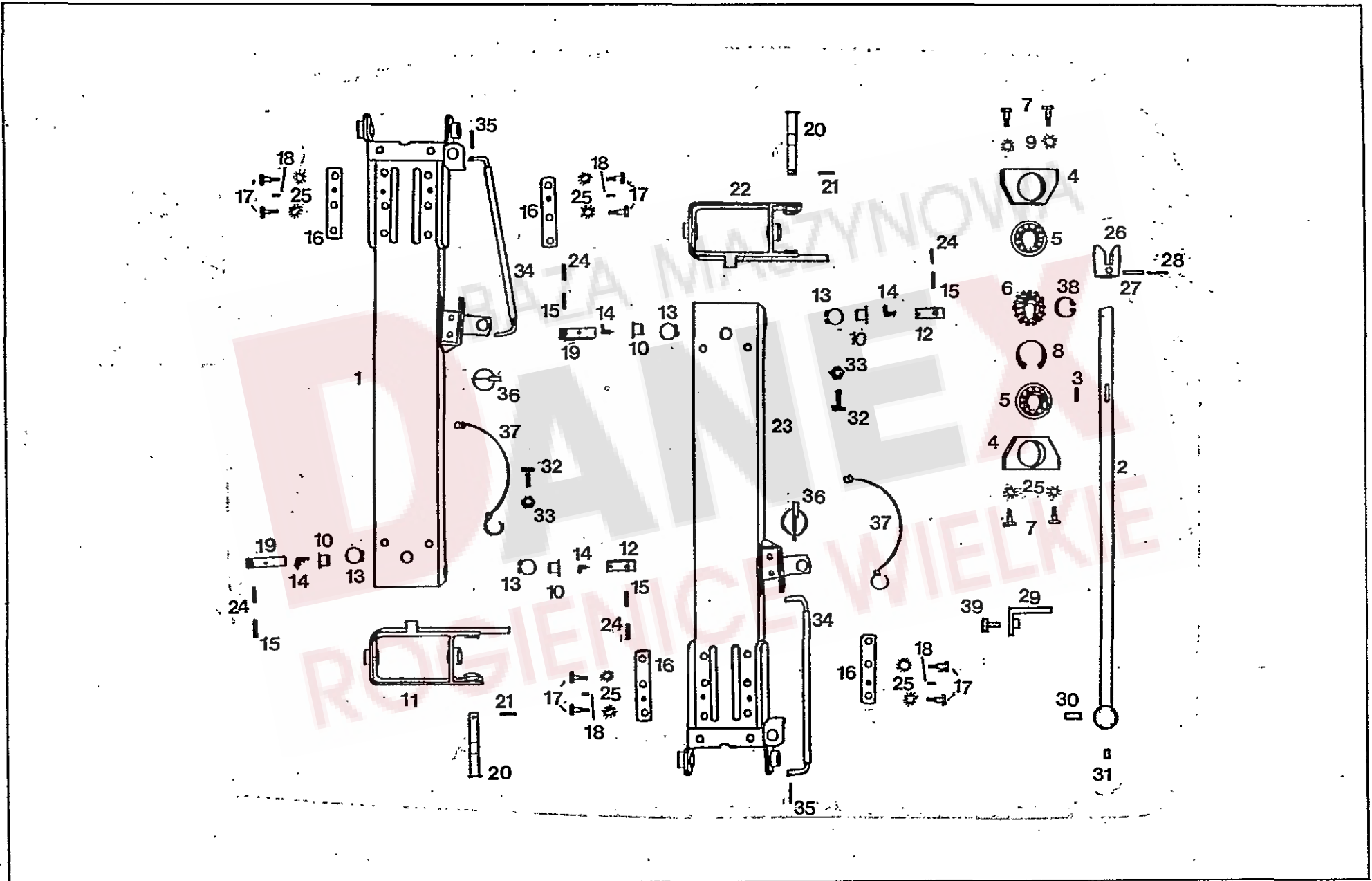

Pos.Nr. Pos.no. Rep. Pos.no.	Bezeichnung des Teiles Description of the part Désignation de la pièce Descrizione del pezzo	As of machine-No. Dès le No. de machine	* ab Masch. Nr. 536	Nr. No. No. No.	TH700 *	TH700D *				
	RAHMEN, RECHTS UND LINKS MITTE	CENTRAL FRAME; LEFT AND RIGHT SIDE OF GEAR	CHASSIS CENTRAL; A GAUCHE ET DROITE DE L'ENGRENAGE							
1	Rahmen, rechts, Mitte	Frame, right side, center	Chassis central, droite	487 980	x					
1	Rahmen, rechts, Mitte	Frame, right side, center	Chassis, central, droite	487 979		x				
2	Antriebswelle, Mitte	Central drive shaft	Arbre d'entraînement central	488 262	x	x				
3	Paßfeder A8x7x36DIN6885	Fitting spring	Ressort de fixation	107 150	x	x				
4	Lagerbock	Bearing bracket	Support de palier	487 548	x	x				
5	Rillenkugellager 6206-2RS DIN 625	Grooved ball bearing	Roulement rainuré à billes	124 757	x	x				
6	Kegelrad Z=15	Bevel wheel	Pignon	487 203	x	x				
7	Paßschraube M12x40 DIN7968-8.8	Screw	Vis de fixation	118 440	x	x				
8	Sicherungsring 62x2DIN 472	Snap ring	Circlip intérieur	107 383	x	x				
9	Zahnscheibe 13,2DIN6797 ZN3	Washer	Rondelle dentée	105 524	x	x				
10	Büchse	Bush	Douille	120 778	x	x				
11	Rechter Bügel	Bracket, right side	Etrier droit	487 927	x	x				
12	Scharnierbolzen	Hinge pin	Boulon de charnière	486 987	x	x				
13	Sicherungsring 28x2 DIN471	Snap ring	Circlip extérieur	118 973	x	x				
14	Kegelschmiernippel CM8x1 DIN 71412 SFG	Cónical grease nipple	Graisser conique	116 749	x	x				
15	Spannhülse 8x40DIN 1481	Clamping sleeve	Douille de serrage	107 465	x	x				
16	Verstärkungsleiste	Reinforcement plate	Plaque de renforcement	487 760	x	x				
17	6kt.-Schraube M12x25DIN933-8.8	Hexagonal bolt	Vis à 6 pans	107 738	x	x				
18	Spannhülse 8x30 DIN1481	Clamping sleeve	Douille de serrage	108 745	x	x				
19	Scharnierbolzen	Hinge pin	Boulon de charnière	487 976	x	x				
20	Bolzen	Pin	Boulon	487 000G	x	x				
21	Spannhülse 8x40 DIN1481	Clamping sleeve	Douille de serrage	107 465	x	x				
22	Bügel, links	Bracket, left side	Etrier gauche	487 928	x	x				
23	Rahmen, links, Mitte	Left frame, Center	Chassis gauche central	487 990G	x					
23	Rahmen, link, Mitte	Left frame, Center	Chassis gauche, central	487 986		x				
24	Spannhülse 5x40 DIN 1481	Clamping sleeve	Douille de serrage	107 441	x	x				
25	Zahnscheibe A 12,5DIN 6797.ZN3	Washer	Rondelle dentée	116 051	x	x				
26	Kupplung	Clutch	Couplage	488 221	x	x				
27	Spannhülse 12x50 DIN1418	Clamping sleeve	Douille de serrage	107 478	x	x				
28	Spannhülse 7x50 DIN 1481	Clamping sleeve	Douille de serrage	105 463	x	x				
29	Stützwinkel gepunktet	Support angle, pointed	Angle de support pointilé	488 254	x	x				
30	Bolzen	Pin	Boulon	121 834	x	x				
31	Gewindestift, Verbus-plus	Threaded pin	Boulon fileté	126 159	x	x				
32	6kt.-Schraube M16x40 DIN933-8.8 A1A	Hexagonal bolt	Vis à 6 pans	109 471	x	x				
33	6kt.-Mutter M16 DIN 936-8 A1A	Hexagonal nut	Ecrou à 6 pans	109 239	x	x				
34	Strebe	Bar	Barre	487 695	x	x				
35	Spannstift 8x40 DIN 1481	Tension pin	Goupille	107 465	x	x				
36	Klappstecker 6 DIN 11023 ZN3	Folding plug	Esses d'essieu	124 053	x	x				
37	Sicherungsschnur	Safety rope	Cordon d'arrêt	111 895	x	x				
38	Sicherungsring 30x2 DIN471	Snap ring	Circlip extérieur	124 504	x	x				
39	6kt.-Schraube M12x20 DIN933-8.8 A1A	Hexagonal bolt	Vis à 6 pans	124 331	x	x				

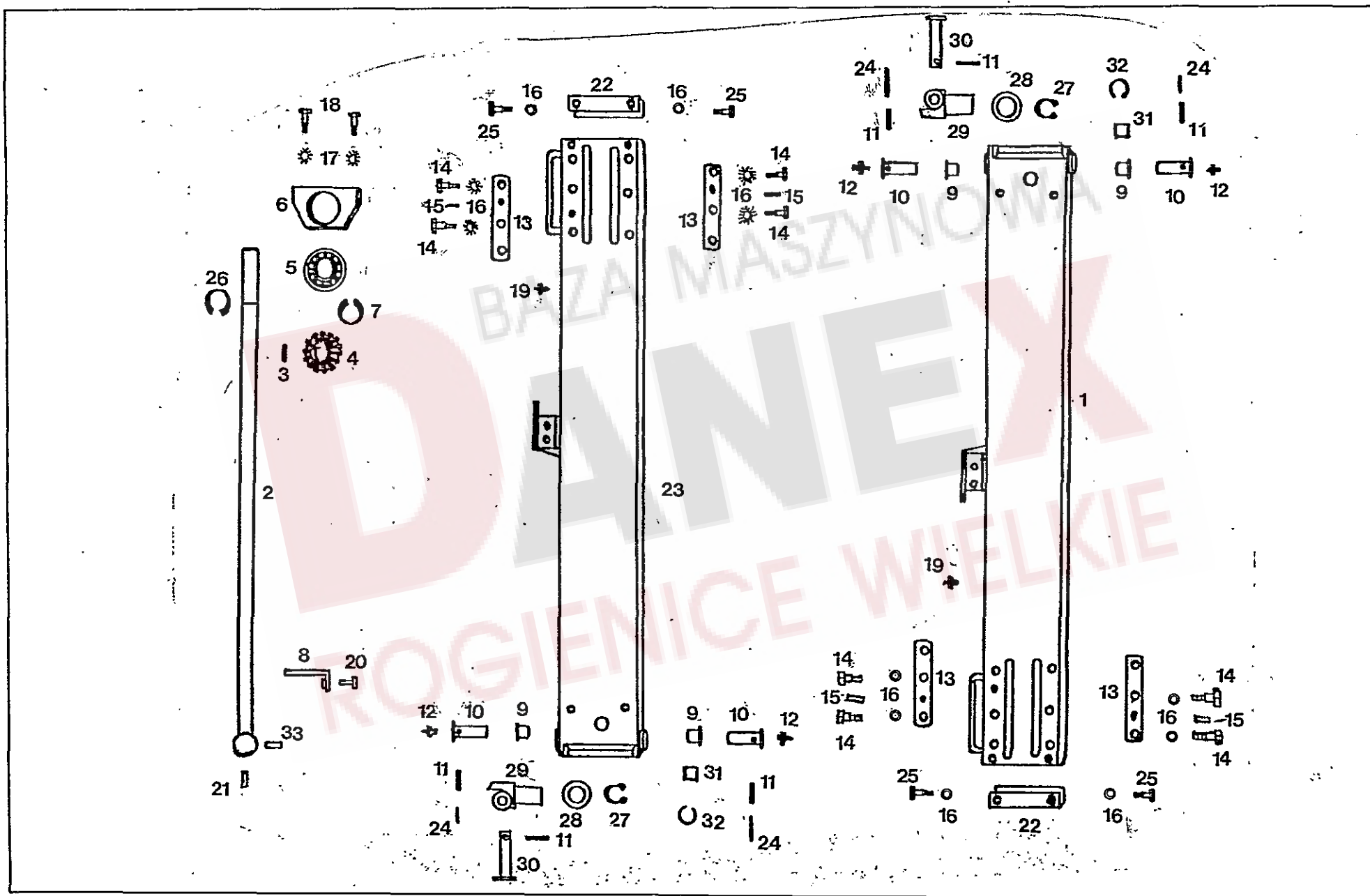



Pos.Nr.	Bezeichnung des Teiles	As of machine-No.	* ab Masch.Nr. 5987	Nr.						
Pos.no.	Description of the part.	Dès le No de machine	** ab Masch.Nr. 7712	No.						
Rep.	Désignation de la pièce		*** ab Masch.Nr. 536	No.						
Pos.no.	Descrizione del pezzo			No.	* TH410	* TH410D	** TH520	** TH520D	***TH700	***TH700D
	RAHMEN, RECHTS UND LINKS AUSSEN	OUTER FRAME RIGHT AND LEFT AND RIGHT SIDE	CHASSIS EXTERIEUR A GAUCHE ET A DROITE							
1	Rahmen rechts außen	Outer frame, right side	Châssis extérieur droite	488 009					x	
	Rahmen rechts außen	Outer frame, right side	Châssis extérieur droite	488 011						x
	Rahmen rechts außen	Outer frame, right side	Châssis extérieur droite	487 413	x	x				
	Rahmen rechts außen	Outer frame, right side	Châssis extérieur droite	487 525			x	x		
2	Antriebswelle, außen	Outer drive shaft	Arbre d'entraînement extérieur	488 263					x	x
	Antriebswelle, außen	Outer drive shaft	Arbre d'entraînement extérieur	488 252	x	x				
	Antriebswelle, außen	Outer drive shaft	Arbre d'entraînement extérieur	488 220			x	x		
3	Paßfeder A8x7x36 DIN 6885 vergütet	Fitting spring	Ressort de fixation	124 502	x	x	x	x	x	x
4	Kegelrad Z=15	Bevel wheel	Pignon	487 203	x	x	x	x	x	x
5	Rillenkugellager 6206-2RS DIN 625	Grooved ball bearing	Roulement rainuré à billes	124 757	x	x	x	x	x	x
6	Lagerbock	Bearing bracket	Support de palier	487 548	x	x	x	x	x	x
7	Sicherungsring 62x2 DIN 472	Snap ring	Circlip intérieur	107 383	x	x	x	x	x	x
8	Stützwinkel	Support angle	Angle de support	488 254	x	x	x	x	x	x
9	Buchse	Bush	Douille	120 778					x	x
10	Scharnierbolzen	Hinge pin	Boulon de charnière	487 237					x	x
11	Spannstift 8x40 DIN 1481	Tension pin	Goupille	107 465	x	x	x	x	x	x
12	Kegelschmiernippel AM6DIN 71412	Conical grease nipple	Graisseur conique	108 294					x	x
13	Verstärkungsleiste	Reinforcement plate	Plaque de renforcement	487 760	x	x	x	x	x	x
14	6kt.-Schraube M12x25 DIN 933-8.8A1A	Hexagonal bolt	Vis à 6 pans	107 738	x	x	x	x	x	x
15	Spannstift 8x30 DIN1481	Tension pin	Goupille	108 745	x	x	x	x	x	x
16	Scheibe 13 DIN 125 ZN 3	Washer	Rondelle dentée	105 186	x	x	x	x	x	x
17	Zahnscheibe 13,2DIN6797-ZN3	Washer	Rondelle dentée	105 524	x	x	x	x	x	x
18	Paßschraube M12x40 DIN7968-8.8	Screw	Vis de fixation	118 440	x	x	x	x	x	x
19	Kegelschmiernippel AM8x1 DIN 71412SFG	Conical grease nipple	Graisseur conique	108 292	x	x	x	x	x	x
20	6kt.-Schraube M12x20 DIN933-8.8A1A V.-p	Hexagonal bolt	Vis à 6 pans	124 331	x	x	x	x	x	x
21	Gewindestift M6x8 DIN913-45 V.-p	Threaded pin	Boulon fileté	126 159	x	x	x	x	x	x
22	Deckel	Cover	Couvercle	487 649	x	x	x	x	x	x
23	Rahmen, links außen	Outer frame, left side	Châssis extérieur gauche	488 010					x	
	Rahmen, links außen	Outer frame, left side	Châssis extérieur gauche	488 012						x
	Rahmen, links außen	Outer frame, left side	Châssis extérieur, gauche	487 414	x	x				
	Rahmen, links außen	Outer frame, left side	Châssis extérieur gauche	487 526			x	x		
24	Spannstift 5x40 DIN1481	Tension pin	Goupille	107 441					x	x
25	6kt.-Schraube M12x20 DIN933-8.8A1A Verb.pl.	Hexagonal bolt	Vis à 6 pans	124 331	x	x	x	x	x	x
26	Sicherungsring 30x2DIN 471	Snap ring	Circlip extérieur	124 504	x	x	x	x	x	x
27	Sicherungsring 42x1,75 DIN 471	Snap ring	Circlip extérieur	108 384	x	x	x	x		
28	Scheibe	Shim	Rondelle	238 009	x	x	x	x		
29	Scharnierstück	Hinge piece	Pièce de charnière	488 073	x	x	x	x		
30	Bolzen	Pin	Boulon	487 553	x	x	x	x		
31	Aufspannbuchse AG28/20x28DIN1499	Tensioning bushing	Douille de fixation	124 395	x	x	x	x		
32	Sprengring S820	Ring	Bague	124 778	x	x	x	x		
33	Bolzen	Pin	Boulon	121 834	x	x	x	x	x	x

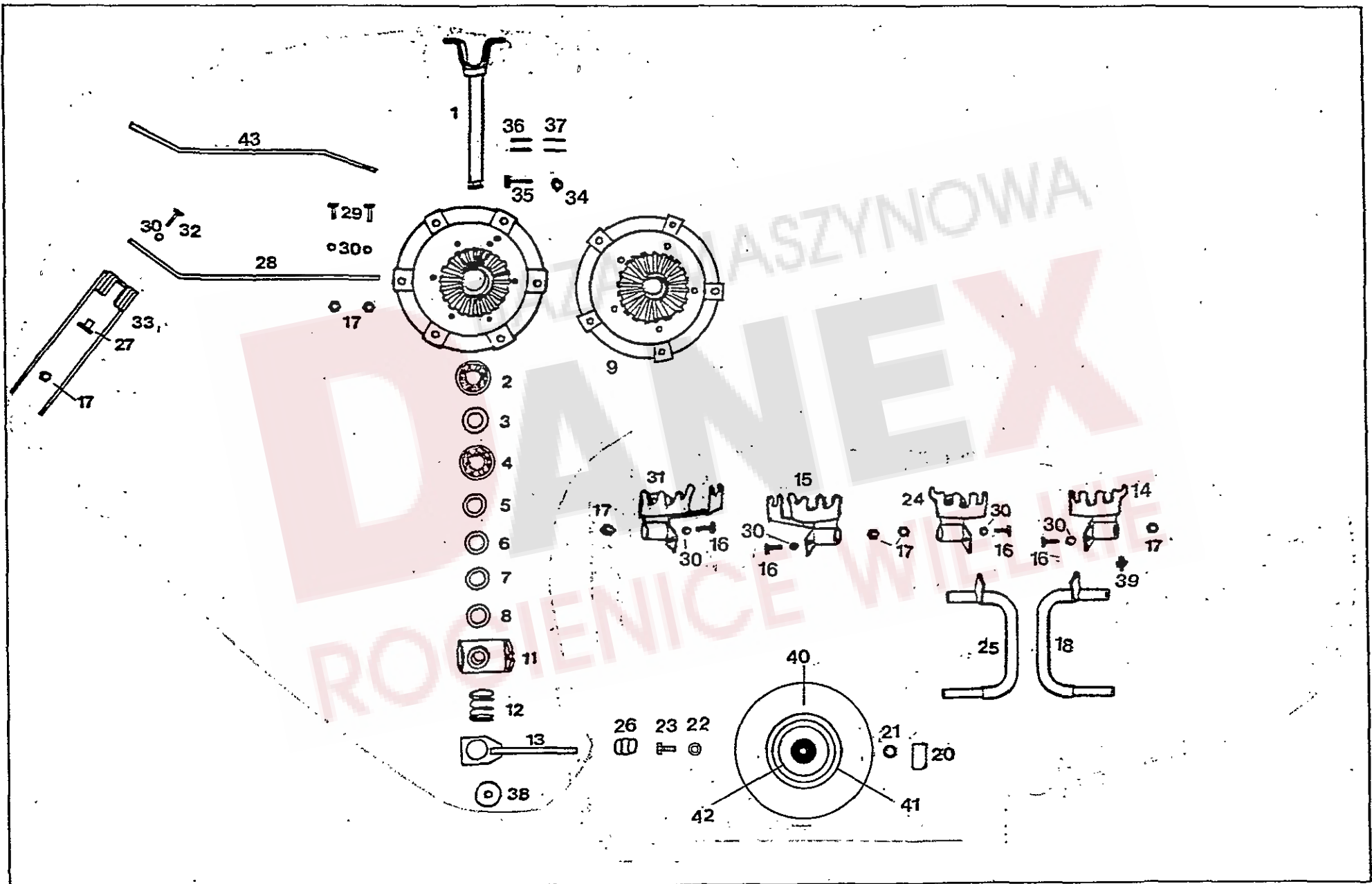

Pos.Nr. Pos.no. Rep. Pos.no.	Bezeichnung des Teiles Description of the part Désignation de la pièce Descrizione del pezzo	As of Machine-No. Dés le No de machine	* ab Masch.-Nr. 5987 ** ab Masch.-Nr. 7712 *** ab Masch.-Nr. 536	Nr. No. No. No.	TH410	TH410D	TH520	TH520D	TH700	TH700D
	<b>Kreisel mit Laufradachse</b>	<b>Rotor with track wheel axle</b>	<b>Plateau rotatif avec axe de roue</b>		*	*	**	**	***	***
1	Achse, geschw.	Welded axle	Axe soudée	487 481G	•	•	•	•	•	•
2	Rillenkugellager 6207-2 RS DIN 625	Grooved ball bearing	Roulement rainuré à billes	124 758	•	•	•	•	•	•
3	Stützscheibe S 50x62 DIN 988	Support plate	Plaque de support	124 330	•	•	•	•	•	•
4	Rillenkugellager 6007-2 RS DIN 625	Grooved ball bearing	Roulement rainuré à billes	126 429	•	•	•	•	•	•
5	Paßscheibe 35x45x1,0 DIN 988 ZN 3	Fitting plate	Rondelle de fixation	120 985	•	•	•	•	•	•
6	Paßscheibe 35x45x0,5 DIN 988 ZN 3 (n. Bedarf)	Fitting plate	Rondelle de fixation	126 375	•	•	•	•	•	•
7	Paßscheibe 35x45x0,2 DIN 988 (n. Bedarf)	Fitting plate	Rondelle de fixation	124 436	•	•	•	•	•	•
8	Scheibe	Washer	Rondelle	487 461	•	•	•	•	•	•
9	Kreisel, geschw.	Rotor, welded	Plateau rotatif, soudé	487 821G	•	•	•	•	•	•
10	Kreisel, geschw.	Rotor, welded	Plateau rotatif, soudé	487 479G	•	•	•	•	•	•
11	Raste	Lock	Verrouillage	487 464	•	•	•	•	•	•
12	Druckfeder	Compression spring	Ressort poussoir	121 066	•	•	•	•	•	•
13	Hebel, geschw.	Welded handle	manette soudée	487 467G	•	•	•	•	•	•
14	Segment, rechts	Right segment	Sègment droit	487 872	•	•	•	•	•	•
15	Segment, links	Left segment	Sègment, gauche	488 100G	•	•	•	•	•	•
16	6kt.-Schraube M 12x30 DIN 933-10.9 A1A	Hexagonal bolt	Vis à 6 pans	117 848	•	•	•	•	•	•
17	Sicherungsmutter VM 12 DIN 980-10 A1A	Retaining nut	Ecrou de maintien	124 710	•	•	•	•	•	•
18	Laufachse, rechts	Traversing axle, right side	Axe de roulement, droite	488 331	•	•	•	•	•	•
20	Schutzscheibe, hinten	Protection plate, rear	Plaque de protection arrière	487 652	•	•	•	•	•	•
21	Scheibe	Washer	Rondelle	240 309	•	•	•	•	•	•
22	Scheibe	Washer	Rondelle	464 006	•	•	•	•	•	•
23	6kt.-Schraube M12x20 DIN 933-8.8A1A verb.-pl.	Hexagonal bolt	Vis à 6 pans	124 331	•	•	•	•	•	•
24	Segment, links	Left side segment	Sègment, gauche	487 873	•	•	•	•	•	•
25	Laufachse, links	Traversing axle, left side	Axe de roulement gauche	488 332	•	•	•	•	•	•
26	Abschlusskappe	Sealing cap	Chapeau de fermeture	121 327	•	•	•	•	•	•
27	Unterlage	Support	Support en haut	487 380	•	•	•	•	•	•
28	Zinkenarm	Tine arm	Bras de dent	487 402	•	•	•	•	•	•
29	6kt.-Schraube M 12x40 DIN 933-8.8 A1A	Hexagonal bolt	Vis à 6 pans	116 630	•	•	•	•	•	•
	6kt.-Schraube M 12x35 DIN 933-8.8 A1A	Hexagonal bolt	Vis à 6 pans	116 629	•	•	•	•	•	•
30	Scheibe 13 DIN 125 ZN 3	Washer	Rondelle	105 186	•	•	•	•	•	•
31	Segment, rechts	Right side segment	Sègment droit	488 099G	•	•	•	•	•	•
32	Befestigungsschraube M 12x45, Gew.Länge 18 mm	Screw	Vis	121 170	•	•	•	•	•	•
33	Federzinken 126 167	Spring tine	Dent flexible	487 922	•	•	•	•	•	•
33	Federzinken 124 966	Spring tine	Dent flexible	488 072	•	•	•	•	•	•
34	Sicherungsmutter VM 8 DIN 980-8 A1A	Retaining nut	Ecrou de maintien	108 531	•	•	•	•	•	•
35	6kt.-Schraube M 8x60 DIN 931-8.8 A1A	Hexagonal bolt	Vis à 6 pans	124 156	•	•	•	•	•	•
36	Spannstift 8x50 DIN 1481	Tension pin	Goupille	107 467	•	•	•	•	•	•
37	Spannstift 5x50 DIN 1481	Tension pin	Goupille	107 443	•	•	•	•	•	•
38	Scheibe	Washer	Rondelle	482 084	•	•	•	•	•	•
39	Kegelschmiernippel AM 8x1 DIN 71412	Conical grease nipple	Graisseur conique	108 292	•	•	•	•	•	•
40	Decke 15x6.00-6 Impl. 4 PR T 510	Cover	Couvercle	121 609	•	•	•	•	•	•
41	Schlauch 140-6 TR 13	Tyre	Roue	121 610	•	•	•	•	•	•
42	Felge 4,50 Ax6 m. 2 Rillenkugellagern	Rim	Jante	121 608	•	•	•	•	•	•
43	Zinkenarm	Tine arm	Bras de dent	488 087	•	•	•	•	•	•
	Zinkenarm	Tine arm	Bras de dent	487 408	•	•	•	•	•	•

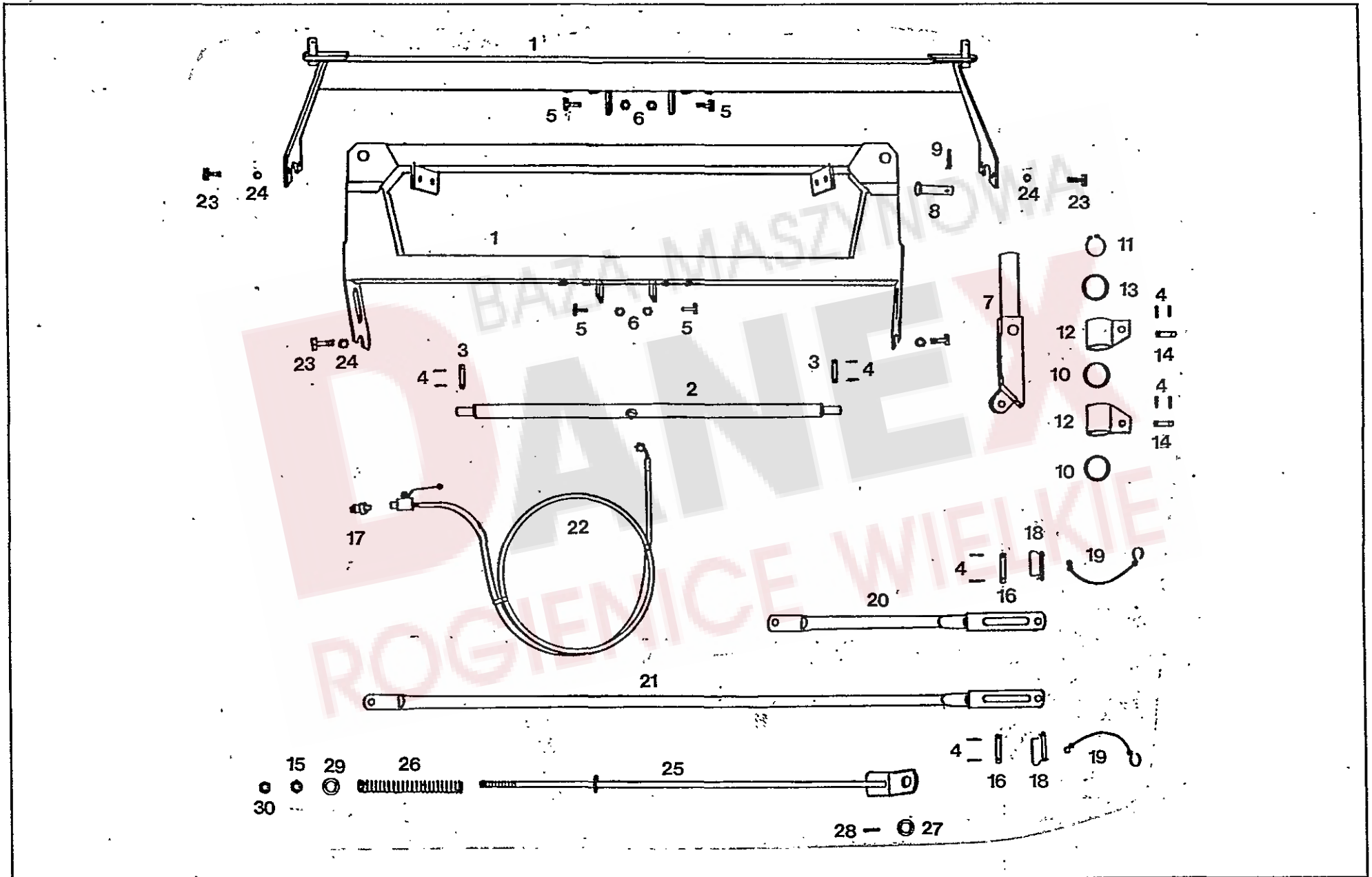

Pos.Nr. Pos.no. Rep. Pos.no.	Bezeichnung des Teiles Description of the part. Désignation de la pièce Descrizione del pezzo	As of machine-No. Dés. le No. de machine	* ab Masch. Nr. 5987. ** ab Masch. Nr. 7712 *** ab Masch. Nr. 536	Nr. No. No.	* TH410D	** TH520D	***TH700D			
	<b>HYDRAULIK MIT ZUBEHÖR</b>	<b>HYDRAULIC SYSTEM WITH ACCESSORIES</b>	<b>SYSTEME HYDRAULIQUE AVEC DES ACCESSOIRES</b>							
1	Querrohr zum Dreipunktbock Träger, geschw.	Crossbar to the 3-point headrack Welded support	Tube traverse au support 3-point Porteur soudé	487 863 487 436			x			
2	Träger, geschw.	Welded support	Porteur soudé	487 432G	x	x				
3	Hydraulikzylinder	Hydraulic cylinder	Vérin hydraulique	487 369G				x		
4	Bolzen	Bolt	Boulon	487 337				x		
5	Spannstift 5x24DIN1481 ZN3	Tension pin	Goupille	107 453				x		
6	6kt.-Schraube M12x30DIN933-8.8 A1A	Hexagonal bolt	Vis à 6 pans	116 628	x	x	x	x		
7	Sicherungsmutter VM12DIN980-8A1A	Retaining nut	Ecrou de maintien	108 589	x	x	x	x		
8	Schwenkrohr, geschw.	Pivoting tube	Tube pivotante	487 326G				x		
9	Bolzen, geschw.	Bolt	Boulon	487 348G				x		
10	Spannstift 6x40DIN1481 ZN3	Tension pin	Goupille	107 452				x		
11	Scheibe	Plate	Rondelle	487 376				x		
12	Sicherungsring 50x2DIN471	Snap ring	Circlip extérieur	108 587				x		
13	Rohr, geschw.	Welded tube	Tube soudée	487 345				x		
14	Scheibe	Plate	Rondelle	354 560				x		
15	Bolzen	Bolt	Boulon	487 363				x		
16	6kt.-Mutter M16DIN934-6A1A	Hexagonal nut	Ecrou à 6 pans	107 811	x	x				
17	Bolzen	Bolt	Boulon	487 364				x		
18	Einschraubstutzen L10M DIN3901	Screw	Vis	120 054				x		
19	Federsteckbolzen	Clip-on bolt	Axe de réglage à ressort	106 857				x		
20	Sicherungsseil	Safety rope	Cordon d'arrêt	490 357				x		
21	Strebe, kurz	Short strut	Barre courte	487 353G				x		
22	Strebe, lang	Long strut	Barre longue	487 354G				x		
23	Hydraulikleitung	Hydraulic cable	Conduit hydraulique	120 034G				x		
24	6kt.-Schraube M12x25 DIN933-8.8A1A	Hexagonal bolt	Vis à 6 pans	116 627	x	x	x			
25	Federring A12DIN127	Washer	Bague flexible	118 070	x	x	x			
26	Gewindestange, geschw.	Threaded bar	Barre filetée	487 496G	x	x				
27	Druckfeder	Compression spring	Ressort poussoir	121 096	x	x				
28	Scheibe	Plate	Rondelle	18 221	x	x				
29	Spannstift 6x40 DIN 1481 ZN 3	Tension pin	Goupille	107 452	x	x				
30	Scheibe	Plate	Rondelle	226 230	x	x				
	Sicherungsmutter VM16DIN980-8 A1A	Retaining nut	Ecrou de maintien	116 699	x	x				

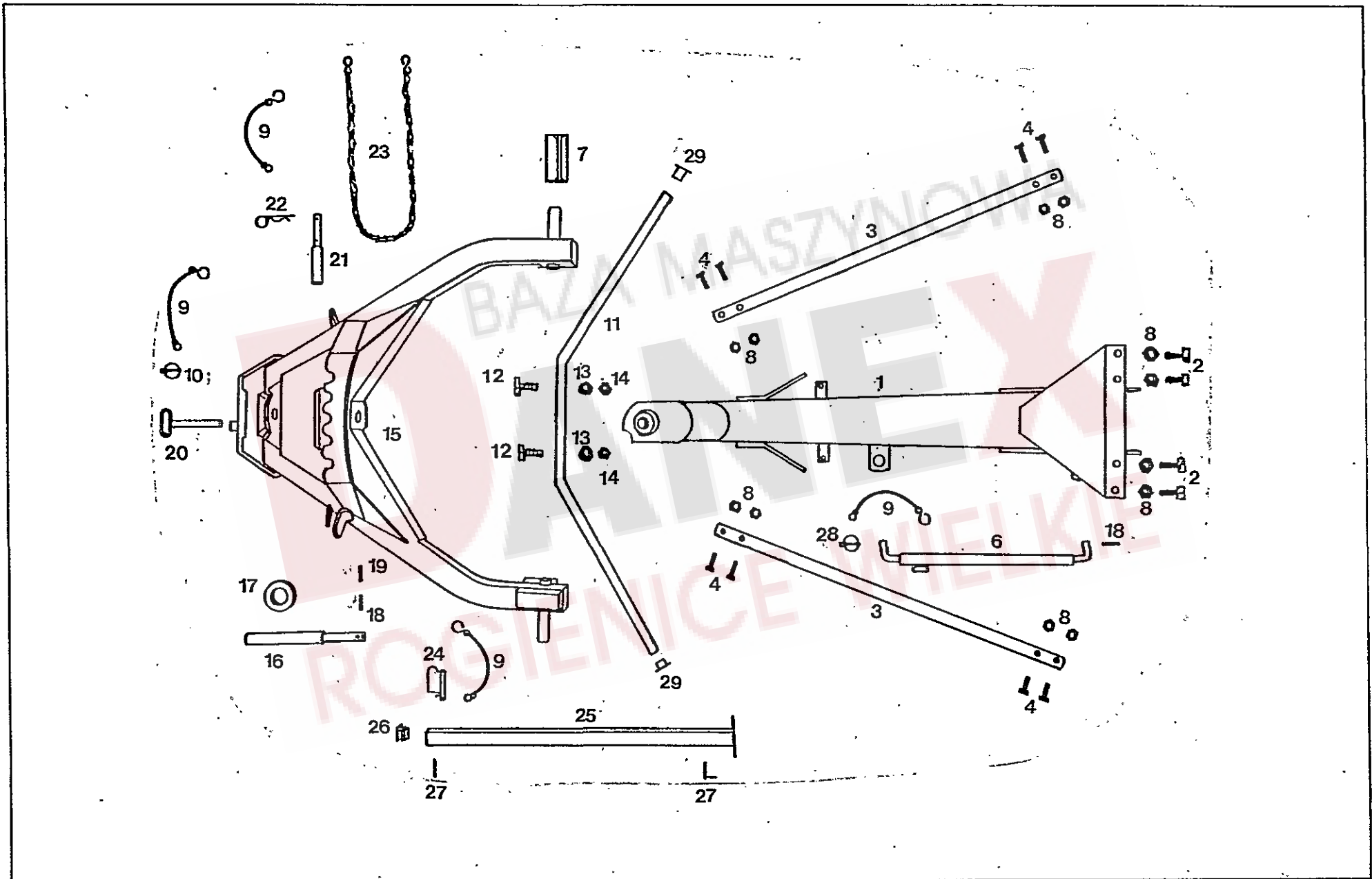

Pos.Nr. Pos.no. Rep. Pos.no.	Bezeichnung des Teiles Description of the part Désignation de la pièce Descrizione del pezzo	As of machine-No. Dès le No. de Machine	1) ab Masch.Nr. 5987. 2) ab Masch.Nr. 7712 3) ab Masch.Nr. 536	Nr. No. No. No.	1) TH410D	2) TH520D	3) TH700D			
	<b>DREIPUNKTBOCK MIT ZUBEHÖR</b>									
	<b>3-POINT HEADRACK WITH ACCESSORIES</b>									
	<b>ATTELAGE TROIS POINTS AVEC DES ACCESSOIRES</b>									
1	Verbindungsprofil, geschw.	Connecting profile, welded		487 859G						x
1	Verbindungsprofil, geschw.	Connecting profile, welded		487 495G	x	x				
2	6kt.-Schraube M12x90 DIN931-8.8 A1A	Hexagonal bolt		116 536	x	x				
3	Strebe	Bar		487 866						x
4	6kt.-Schraube M12x35 DIN933-8.8A1A	Hexagonal bolt		107 740						x
5										
6	Strebe mit Kettenglied	Strut with chain link		487 695G						x
7	Aufspannbuchse AG28x22x40	Tensioning bushing		109 470	x	x				
8	Sicherungsmutter VM12DIN980-8 A1A	Retaining nut		108 589	x	x	x			
9	Sicherungsschnur (490 357)	Retaining rope		111 895	x	x	x			
10	Rohrklappsplint 6x30	Cotter pin		124 287	x	x	x			
11	Schutzstrebe	Protection strut		487 632	x	x	x			
12	6kt.-Schraube M8x40 DIN931-8.8A1A	Hexagonal bolt		116 513	x	x	x			
13	Scheibe 9DIN 126-ZN3	Plate		115 991	x	x	x			
14	Sicherungsmutter VM8 DIN980-8A1A	Retaining nut		108 531	x	x	x			
15	Dreipunktbock, geschw.	3-point headrack, welded		488 042G						x
15	Dreipunktbock, geschw.	3-point headrack, welded		487 587G	x	x				
16	Bolzen	Bolt		487 482G	x	x	x			
17	Rolle	Roll		487 514	x	x	x			
18	Spannstift 8x40 DIN1481	Tension pin		107 465	x	x	x			
19	Spannstift 5x40 DIN1481	Tension pin		107 441	x	x	x			
20	Bolzen, geschw.	Welded pin		487 429G	x	x				
21	Oberlenkerstufenbolzen 25x19x160	Bolt of upper link assembly		124 295	x	x	x			
22	Federstecker 5DIN 11024 ZN3	Plug		115 916	x	x	x			
23	Knotenkette, 2,8 DIN 5686-11 Glieder 500 mm lang (491 146)	Link chain (11 links)		117 244	x	x	x			
24	Federsteckbolzen 12x55	Clip-on bolt		106 857	x	x	x			
25	Stütze, geschw.	Support, welded		478 324G	x	x	x			
26	Kunststoffkappe	Plastic hat		478 786	x	x	x			
27	Spannstift 6x45 DIN1481	Tension pin		107 453	x	x	x			
28	Klappstecker 6 DIN11023 ZN3	Folding plug		124 053						x
29	Verschlußkappe	Sealing hat		124 290	x	x	x			

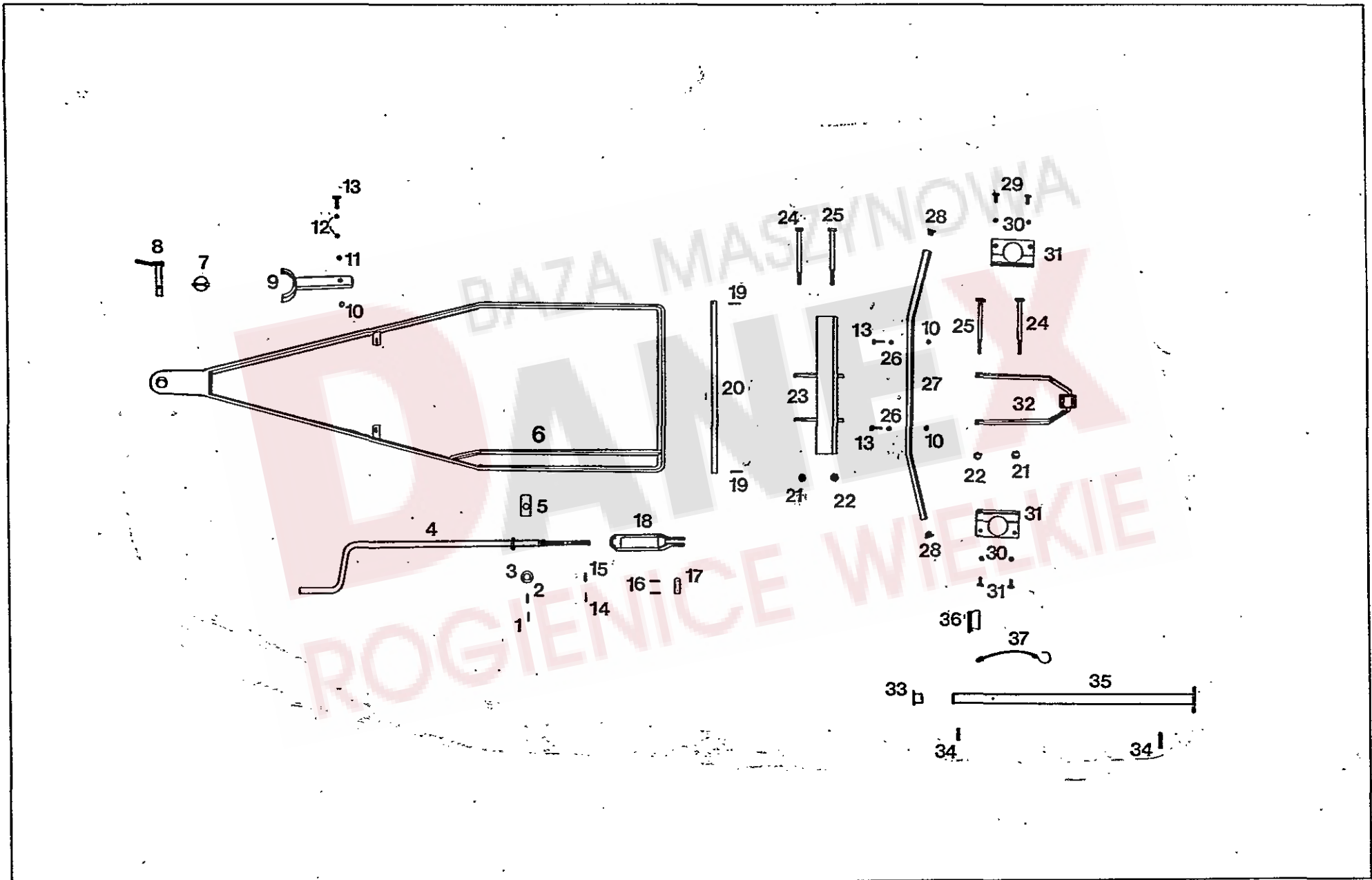



Pos.Nr. Pos.no. Rep. Pos.no.	Bezeichnung des Teiles Description of the part. Désignation de la pièce Descrizione del pezzo	As of machine-No. Dès le No. de machine	* ab Masch. Nr. 5987 ** ab Masch. Nr. 7712	Nr. No. No. No.	TH410 *	TH520 **					
	<b>DEICHEL MIT ZUBEHÖR, VOLLST.</b>	<b>DRAWBAR WITH ACCESSORIES COMPLETE</b>	<b>TIMON AVEC ACCESSOIRES COMPLET</b>								
1	Spannhülse 3,5x40 DIN1481	Clamping sleeve	Douille de serrage	107 425	x	x					
2	Spannhülse 6x40 DIN1481	Clamping sleeve	Douille de serrage	107 452	x	x					
3	Stellingring	Washer	Bague	491 076	x	x					
4	Stellspindel, geschw.	Retaining tongue, welded	Collier de fixation, soudé	487 647G	x	x					
5	Gelenknuß	Hinge nut	Pièce d'articulation	487 213	x	x					
6	Deichsel, geschw.	Drawbar, welded	Timon, soudé	487 459	x	x					
7	Klappstecker 8DIN 11023ZN3	Folging plug	Esses d'essieu	109 179	x	x					
8	Steckbolzen, geschw.	Clip-on bolt	Axe de réglage	355 939G	x	x					
9	Gelenkwellenhalter, geschw.	p.t.o.-shaft holder, welded	Support de l'arbre de transmission	487 643G	x	x					
10	Sicherungsmutter VM8 A1A DIN990	Retaining nut	Ecrou de maintien	108 531	x	x					
11	Federscheibe B 10DIN 137 ZN3	Spring plate	Plaque de ressort	115 997	x	x					
12	Scheibe 8,4 DIN 125 ZN3	Washer	Rondelle	115 972	x	x					
13	6kt.-Schraube M8x40 DIN931-8.8A1A	Hexagonal bolt	Vis à 6 pans	116 513	x	x					
14	Spannhülse 3,5x30 DIN 1481	Clamping sleeve	Douille de serrage	108 415	x	x					
15	Spannhülse 6x30 DIN1481	Clamping sleeve	Douille de serrage	107 449	x	x					
16	Spannhülse 5x36 DIN 1481	Clamping sleeve	Douille de serrage	107 440	x	x					
17	Bolzen	Bolt	Boulon	487 646	x	x					
18	Gabel, geschw.	Fork, welded	Fourchette, soudée	487 457G	x	x					
19	Spannhülse 5x40DIN 1481	Clamping sleeve	Douille de serrage	107 441	x	x					
20	Bolzen	Bolt	Boulon	487 460	x	x					
21	Sicherungsmutter VM14 DIN 980-8A1A	Retaining Nut	Ecrou de maintien	109 363	x	x					
22	Sicherungsmutter VM16DIN 980-8A1A	Retaining nut	Ecrou de maintien	116 699	x	x					
23	Träger, geschw.	Carrier, welded	Bras portant, soudé	487 446G	x	x					
24	6kt.-Schraube M14x180 DIN 931-8.8A1A	Hexagonal bolt	Vis à 6 pans	124 268	x	x					
25	6kt.-Schraube M16x180 DIN 931-8.8A1A	Hexagonal bolt	Vis à 6 pans	116 486	x	x					
26	Scheibe 9DIN126ZN3	Washer	Rondelle	115 991	x	x					
27	Schutzstrebe	Protection strut	Barre de protection	487 645	x	x					
28	Verschlusskappe(Kunststoff)	Sealing hat	Chapeau de fermeture	124 290	x	x					
29	6kt.-Schraube M12x25 DIN933-8.8A1A	Hexagonal bolt	Vis à 6 pans	116 627	x	x					
30	Federring A12 DIN127	Seal	Bague	118 070	x	x					
31	Anschlagplatte	Stop plate	Plaque de butée	487 631	x	x					
32	Halter, geschw.	Support, welded	Support, soudé	487 666G	x	x					
33	Kunststoffkappe	Plastic hat	Chapeau plastique	478 786	x	x					
34	Spannhülse 6x45 DIN 1481	Clamping sleeve	Douille de serrage	107 453	x	x					
35	Stütze, geschw.	Support, welded	Support soudé	487 271G	x	x					
36	Federsteckbolzen 12x55	Clip-on bolt	Axe de réglage à ressort	106 857	x	x					
37	Sicherungsschnur (111 895)	Retaining rope	Câble de maintien	490 357	x	x					

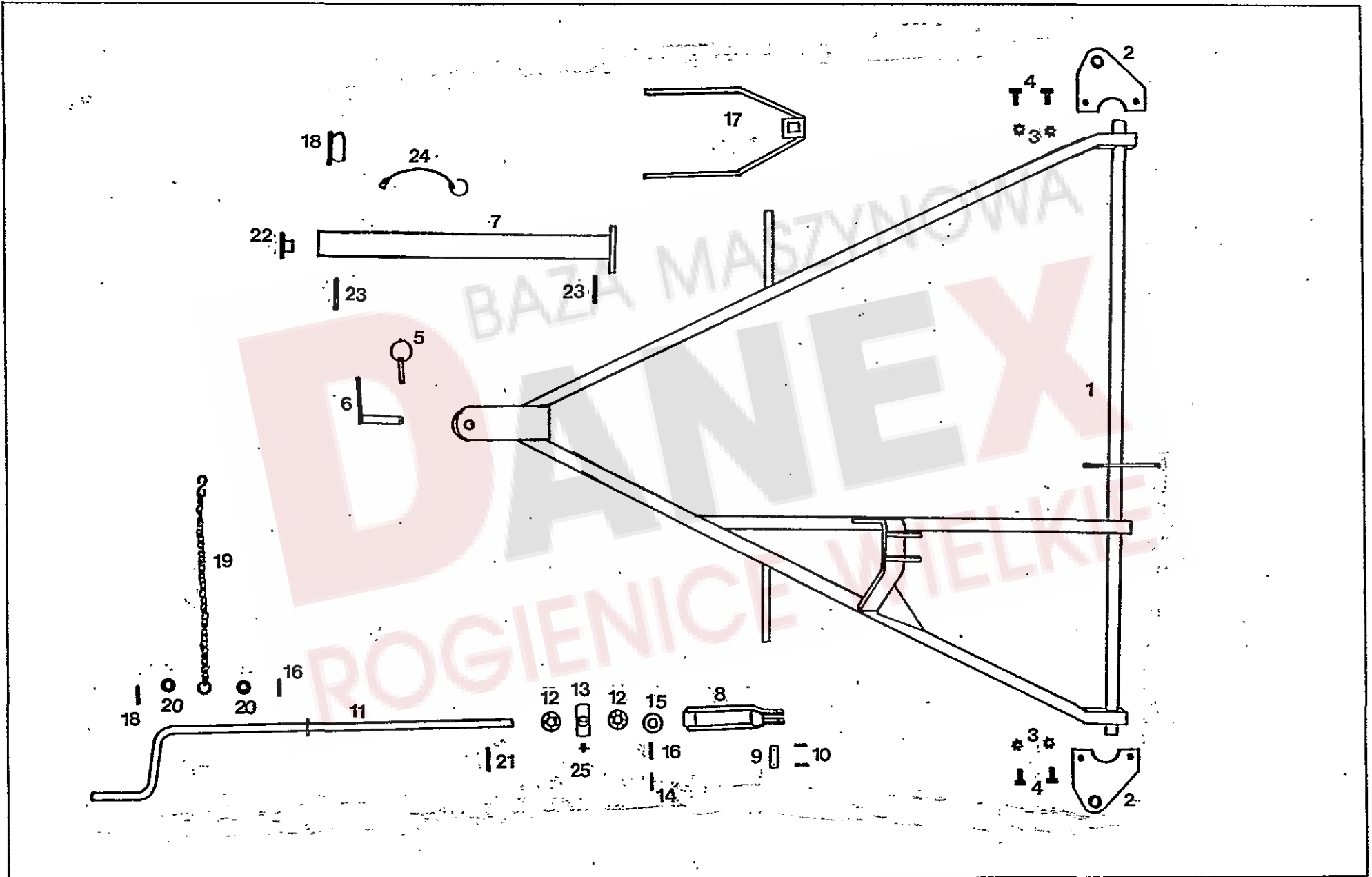

Pos.Nr. Pos.no. Rep. Pos. no.	Bezeichnung des Teiles Description of the part Désignation de la pièce Descrizione del pezzo	* ab Masch-Nr. 536 * as of machine No. 536 * dès le No. de machine 536	Nr. No. No. No.					
	<b>DEICHEL MIT ZUBEHÖR</b>	<b>DRAWBAR WITH ACCESSORIES</b>	<b>TIMON AVEC ACCESSOIRES</b>					
1	Deichsel, geschw.	Drawbar, welded	Timon, soudé	488 051G	x			
2	Scharnierplatte, außen	Hinge plate	Plaque de charnière	488 036	x			
3	Federring A 12DIN127	Flexible ring	Bague flexible	118 070	x			
4	6kt-Schraube M12x25 DIN 933-8.8A1A	Hexagonal bolt	Vis à 6 pans	116 627	x			
5	Klappstecker 8DIN 11023 ZN3	Folding plug	Esses d'essieu	109 179	x			
6	Steckbolzen, geschw.	Stud pin	Axe de réglage	355 939	x			
7	Stütze, geschw.	Support	Support	487 271G	x			
8	Gabel, geschw.	Fork	Fourchette	487 457G	x			
9	Bolzen	Bolt	Boulon	487 646	x			
10	Spannstift 5x36DIN1481	Tension pin	Goupille	107 440	x			
11	Stellspindel	Retaining tongue	Collier de fixation	488 274G	x			
12	Axial-Rillenkugellager KS RA 25	Grooved ball bearing	Roulement rainuré à billes	117 418	x			
13	Gelenknuß	Hinge nut	Pignon de jointure	406 592	x			
14	Spannstift 3,5x40 DIN1481	Tension pin	Goupille	107 452	x			
15	Stellring	Leveling ring	Bague de réglage	491 076	x			
16	Spannstift 6x40 DIN1481	Tension pin	Goupille	107 452	x			
17	Halter, geschw.	Support	Support	488 056	x			
18	Federsteckbolzen 12x55 ABK-F	Clip-on bolt	Axe de réglage à ressort	106 857	x			
19	Knotenkette 2,8 Länge 500 mm	Link chain	Chaîne à joints	121 594	x			
20	Scheibe 23 DIN 125 ZN 3	Washer	Rondelle	115 980	x			
21	Spannstift 6x30 DIN 1481	Tension pin	Goupille	107 449	x			
22	Kunststoffkappe 34x34	Plastic hat	Chapeau plastique	115 527	x			
23	Spannstift 6x45 DIN 1481	Tension pin	Goupille	107 453	x			
24	Sicherungsschnur	Safety cord	Cordon d'arrêt	111 895	x			
25	Kegeischmiernippel AM 8x1 DIN71412	Conical grease nipple	Graisseur conique	108 292	x			

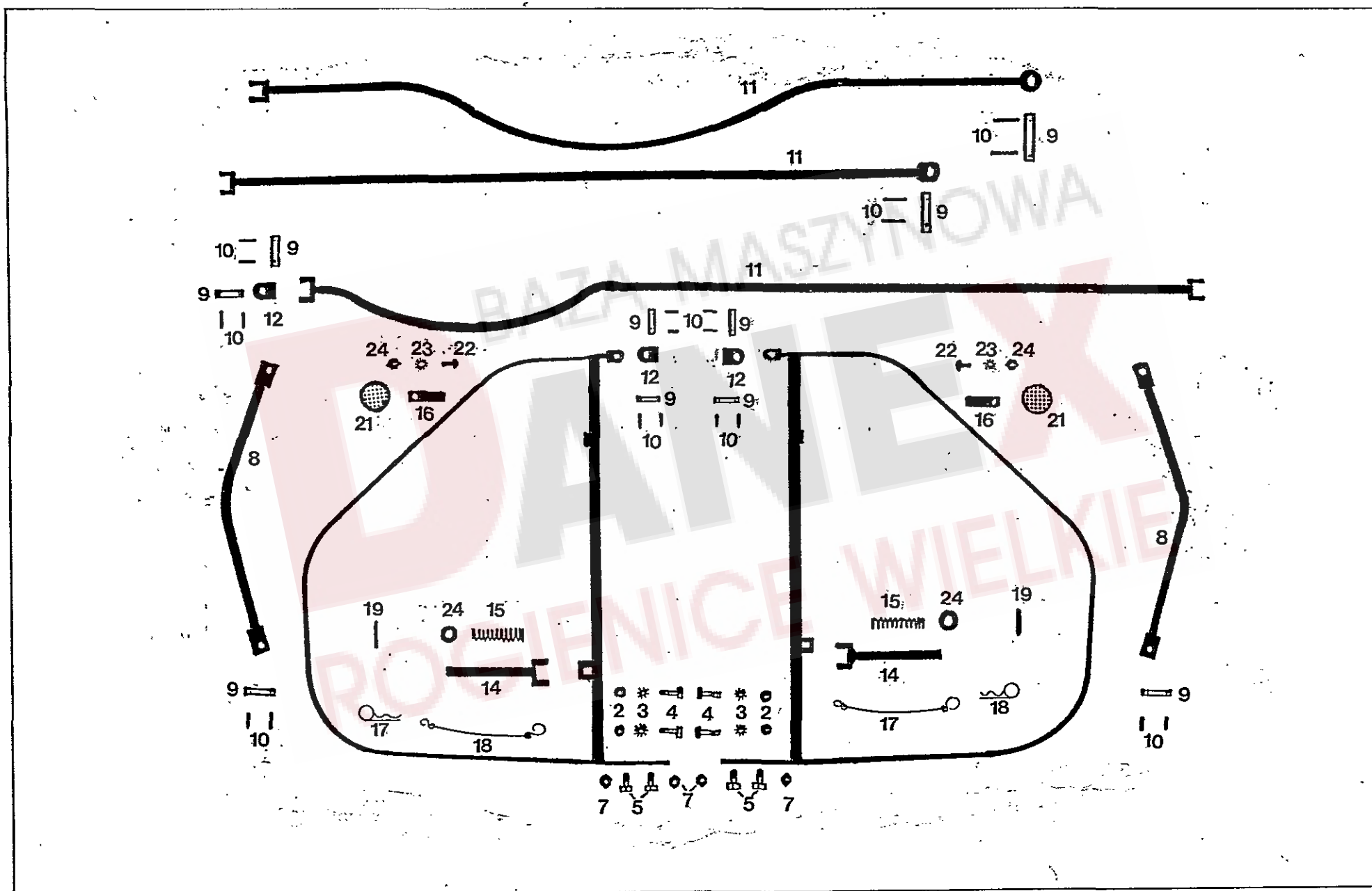

Pos.Nr. Pos.no. Rep. Pos.no.	Bezeichnung des Teiles Description of the part Désignation de la pièce Descrizione del pezzo	As of machine-No. Dès le No de machine	* ab Masch.-Nr. 5987 ** ab Masch.-Nr. 7712 *** ab Masch.-Nr. 536	Nr. No. No. No.	TH410	TH410D	TH520	TH520D	TH700	TH700D
	<b>Schutzbogen mit Streben</b>	<b>Guard with struts</b>	<b>Pièce de protection</b>		*	*	**	**	***	***
1	Schutzbogen, rechts	Right side guard	Pièce de protection, droite	488 177G					•	•
	Schutzbogen, rechts	Right side guard	Pièce de protection, droite	488 174G	•	•				
	Schutzbogen, rechts	Right side guard	Pièce de protection droite	488 169G						
2	Scheibe	Washer	Rondelle	464 006	•	•	•	•	•	•
3	Zahnscheibe A 12,5 DIN 6797 ZN 3	Toothed washer	Rondelle dentée	116 051	•	•	•	•	•	•
4	6kt.-Schraube M72x50 DIN 931-8.8 A1A	Hexagonal bolt	Vis à 6 pans	116 530	•	•	•	•	•	•
5	6kt.-Schraube M 12x30 DIN 933-8.8 A1A	Hexagonal bolt	Vis à 6 pans	116 628	•	•	•	•	•	•
6	Sicherungsmutter VM 8 DIN 980-8 A1A	Retaining nut	Ecrou de maintien	108 531	•	•	•	•	•	•
7	Sicherungsmutter VM 12 DIN 980-8 A1A	Retaining nut	Ecrou de maintien	108 589	•	•	•	•	•	•
8	Querstrebe, geschw.	Transverse strut	Etrier transverseau	488 020G	•	•			•	•
	Querstrebe, geschw.	Transverse strut	Etrier transverseau	487 600G	•	•				
	Querstrebe, geschw.	Transverse strut	Etrier transverseau	487 597G			•	•		
9	Bolzen	Bolt	Boulon	121 389	•	•	•	•	•	•
10	Spannstift 5x24 DIN 1481 ZN 3	Tension pin	Goupille	107 435	•	•	•	•	•	•
11	Längsstrebe, geschw.	Longitudinal strut	Etrier longitudinal	488 029	•	•			•	•
	Längsstrebe, geschw.	Longitudinal strut	Etrier longitudinal	486 976	•	•				
	Längsstrebe, geschw.	Longitudinal strut	Etrier longitudinal	487 598	•	•	•	•		
12	Gelenkstück	Joint piece	Pièce de jointure	486 964	•	•	•	•		•
13	Schutzbogen, links	Left side guard	Pièce de protection, gauche	488 178G	•	•			•	•
	Schutzbogen, links	Left side guard	Pièce di protection, gauche	488 175G	•	•				
	Schutzbogen, links	Left side guard	Pièce de protection, gauche	488 170G			•	•		
14	Verriegelung, geschw.	Lock, welded	Verrouillage, soudé	488 024G					•	•
15	Druckfeder	Compression spring	Ressort de pression	121 617					•	•
16	Halter, links	Support, left side	Support, gauche	487 188	•		•		•	•
17	Sicherungsschnur	Safety cord	Cordon d'arrêt	111 895					•	•
18	Federstecker 5 DIN 11024	Plug	Fiche	115 916					•	•
19	Spannstift 8x65 DIN 1481	Tension pin	Goupille	107 470					•	•
20	Halter, rechts	Support, right side	Support, droite	487 187	•		•		•	•
21	Rückstrahler	Reflector	Catadioptré	111 804	•		•		•	•
22	Flachrundschrabe M 8x25 DIN 603-4.6 A1A	Flat round bolt	Vis plat, rond	116 224	•		•		•	•
23	Scheibe 8,4 DIN 125 ZN 3	Washer	Rondelle	115 972	•		•		•	•
24	Scheibe	Washer	Rondelle	240 309					•	•

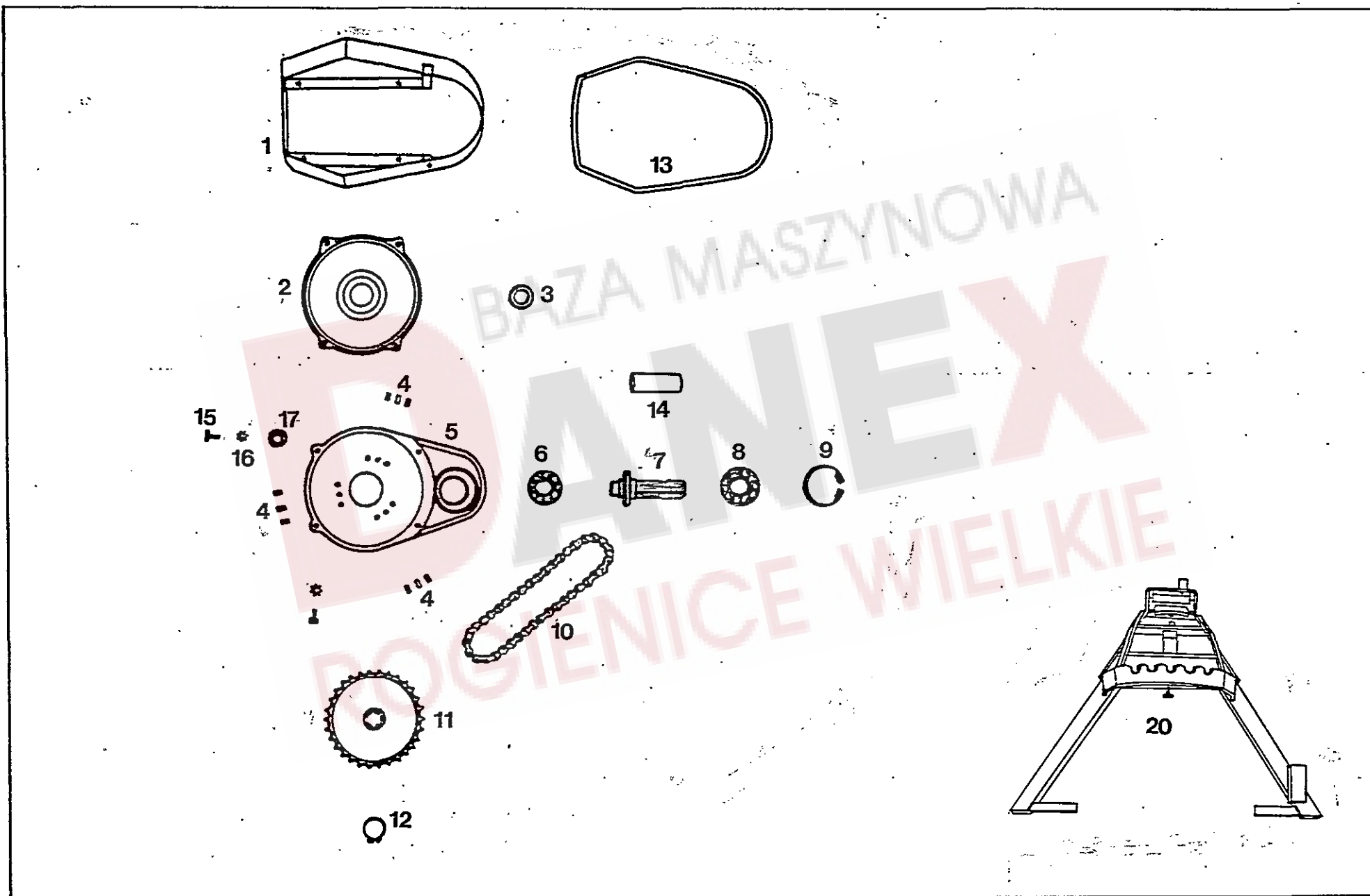

Pos.Nr. Pos.no. Rep. Pos.no.	Bezeichnung des Teiles Description of the part Désignation de la pièce Descrizione del pezzo	As of machine-No. Dés le No de machine	* ab Masch.Nr. 5987 ** ab Masch.Nr. 7712 *** ab Masch.Nr. 536	Nr. No. No.	* TH410	* TH410D	** TH520	** TH520D	*** TH700	*** TH700D
	<b>FLUREIENGETRIEBE MIT SCHUTZ SONDERZUBEHÖR</b>	<b>NIGHT SWATH GEAR WITH GUARD SPECIAL EQUIPMENT</b>	<b>ENGRENAGE POUR ANDAINS AVEC PROTECTEUR EQUIPEMENT SPECIAL</b>	487 637	x	x	x	x	x	x
1	Schutz, gepkt.	Guard	Protecteur	487 442G	x	x	x	x	x	x
2	Getriebedeckel	Gear cover.	Couvercle d'engrenage	486 113G	x	x	x	x	x	x
3	Filzring	Washer	Bague	108 606	x	x	x	x	x	x
4	Gewindestift M10x12 DIN 914	Threaded pin	Goupille fileté	109 205	x	x	x	x	x	x
5	Getriebegehäuse	Gearbox housing	Boîte à vitesse	487 639	x	x	x	x	x	x
6	Rillenkugellager 6206 2RS DIN 625	Grooved ball bearing	Roulement rainuré à billes	105 327	x	x	x	x	x	x
7	Wellenstummel m.Kettenrad Z=10, geschw.	Stub shaft with sprocket wheel	Bout d'arbre avec roue dentée	486 103	x	x	x	x	x	x
8	Rillenkugellager 6207 2RS DIN 625	Grooved ball bearing	Roulement rainuré à billes	108 570	x	x	x	x	x	x
9	Sicherungsring 72x2,5 DIN 472	Snap ring	Circlip intérieur	107 385	x	x	x	x	x	x
10	Präzisionsrollenkette 3/4" x 7/16" t=19,05 39 Glieder einschl. 1 gekröpftes Glied und 1 gerades Verschlussstück	Precision roller chain(39 rolls)	Chaîne à rouleaux de précision (39 rouleaux)	486-178G	x	x	x	x	x	x
11	Kettenrad, geschw. Z=30	Sprocket wheel	Roue dentée	486 107G	x	x	x	x	x	x
12	Sicherungsring 35x1,5 DIN 471	Snap ring	Circlip extérieur	107 367	x	x	x	x	x	x
13	Kantenschutz (115 674)	Edge protection	Protecteur des bords	487 641	x	x	x	x	x	x
14	Zapfwellenschutz	P.t.q. shaft guard	Protecteur de l'arbre de prise de force	124 292	x	x	x	x	x	x
15	6kt.-Schraube M8x20 DIN933-8.8 A1A	Hexagonal bolt	Vis à 6 pans	107 727	x	x	x	x	x	x
16	Zahnscheibe A8,4 DIN 6797 ZN3	Toothed plate	Rondelle dentée	116 049	x	x	x	x	x	x
17	Scheibe 8,4 DIN 125 ZN3	Washer	Rondelle	115 972	x	x	x	x	x	x
	<b>SONDERZUBEHÖR</b>	<b>SPECIAL EQUIPMENT</b>	<b>EQUIPEMENT SPECIAL</b>							
20	Geräte-Dreieck, geschw.	Three-point headrack	Triangle pour matériel	487 661G	x		x			

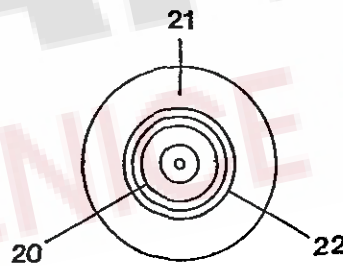
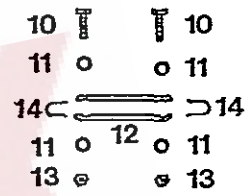
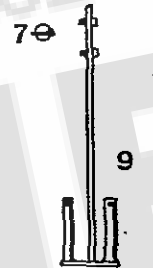
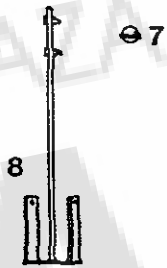
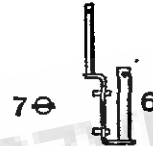
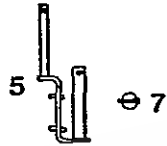
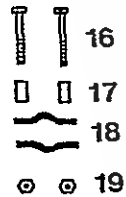
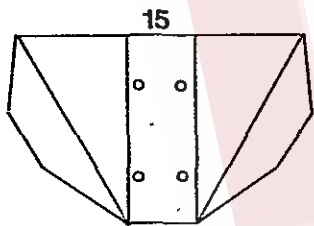
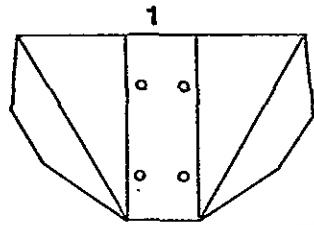



Pos.Nr. Pos.no. Rep. Pos.no.	Bezeichnung des Teiles Description of the part Désignation de la pièce Descrizione del pezzo			Nr. No. No. No.	TH410	TH410D	TH520	TH520D	TH700	TH700D
	<b>Sonderzubehör</b>	<b>Special equipment</b>	<b>Equipement special</b>							
	<b>Garnitur Wickelschutz für Bereifung 3.50-8 und 15/6.00-6</b>	<b>Set of guards for track wheel</b>	<b>Jeu de protection pour roue</b>							
1	Wickelschutz	Guard	Protection	487 663	•	•	•	•		
2	6kt.-Schraube M 8x40 DIN 931-8.8 A1A	Hexagonal bolt	Vis à 6 pans	116 513	•	•	•	•		
3	Schelle	Bracket	Bride	487 662	•	•	•	•		
4	Sicherungsmutter VM 8 DIN 980-8 A1A	Retaining nut	Ecrou de maintien	108 531	•	•	•	•		
	<b>Beleuchtungsgarnitur, vollst.</b>	<b>Lighting set, cpl.</b>	<b>Jeu d'eclairage, cpl.</b>	487 186G	•		•		•	
5	Linker Beleuchtungshalter, geschw.	Left lighting support	Support d'éclairage, gauche	487 182G	•		•		•	
6	Rechter Beleuchtungshalter, geschw.	Right lighting support	Support d'éclairage, droit	487 181G	•		•		•	
7	Klappstecker 5 DIN 1023 ZN 3	Folding plug	Esses d'essieu	109 162	•		•		•	
	<b>Beleuchtungsgarnitur, vollst.</b>	<b>Lighting set, cpl.</b>	<b>Jeu d'eclairage, cpl.</b>	487 194G		•		•		•
8	Linker Beleuchtungshalter, geschw.	Left lighting support	Support d'éclairage, gauche	487 189G		•		•		•
9	Rechter Beleuchtungshalter, geschw.	Right lighting support	Support d'éclairage, droit	487 192G		•		•		•
	<b>Zinkensicherung, vollst.</b>	<b>Safety device for tines, cpl.</b>	<b>Dispositif de securite pour les dents, cpl.</b>	488 320	•	•	•	•	•	•
10	6kt.-Schraube M 8x25 DIN 933-8.8 A1A	Hexagonal bolt	Vis à 6 pans	116 614	•	•	•	•	•	•
11	Scheibe A 9 DIN 126 ZN 3	Washer	Rondelle	115 991	•	•	•	•	•	•
12	Zinkensicherung	Seal	Frein	121 977	•	•	•	•	•	•
13	Sicherungsmütter M 8 DIN 6925 A1A	Retaining nut	Ecrou de maintien	108 531	•	•	•	•	•	•
14	Schelle	Clamp	Collier	488 319	•	•	•	•	•	•
	<b>Garnitur Wickelschutz für Bereifung 16/6.50-8</b>	<b>Set of guards for track wheel</b>	<b>Jeu de protection pour roue</b>	487 677					•	•
15	Wickelschutz	Guard	Protecteur	487 663					•	•
16	6kt.-Schraube M 8x70 DIN 931-8.8 A1A	Hexagonal bolt	Vis à 6 pans	124 279					•	•
17	Distanzbuchse	Distance bush	Douille à distance	487 676					•	•
18	Schelle	clamp	Collier	487 662					•	•
19	Sicherungsmutter VM 8 DIN 980-8 A1A	Retaining nut	Ecrou de maintien	108 531					•	•
	<b>Super-Ballon-Bereifung (6 Stück)</b>	<b>Super-ballon tyres (6 pcs.)</b>	<b>Pneus super ballon (6 pc)</b>	488 059					•	•
20	Felge 5.50 A-8m. 2 Rillenkugellager 6205-2RS	Rim with 2 grooved ball bearing	Jante ave 2 roulements rainurés	121 090					•	•
21	Decke 16/6.50-8 Impl. 4 PR-T 510	Tyre	Roue	121 091					•	•
22	Schlauch 16/6.50-8 TR 13	Tyre	Roue	121 092					•	•

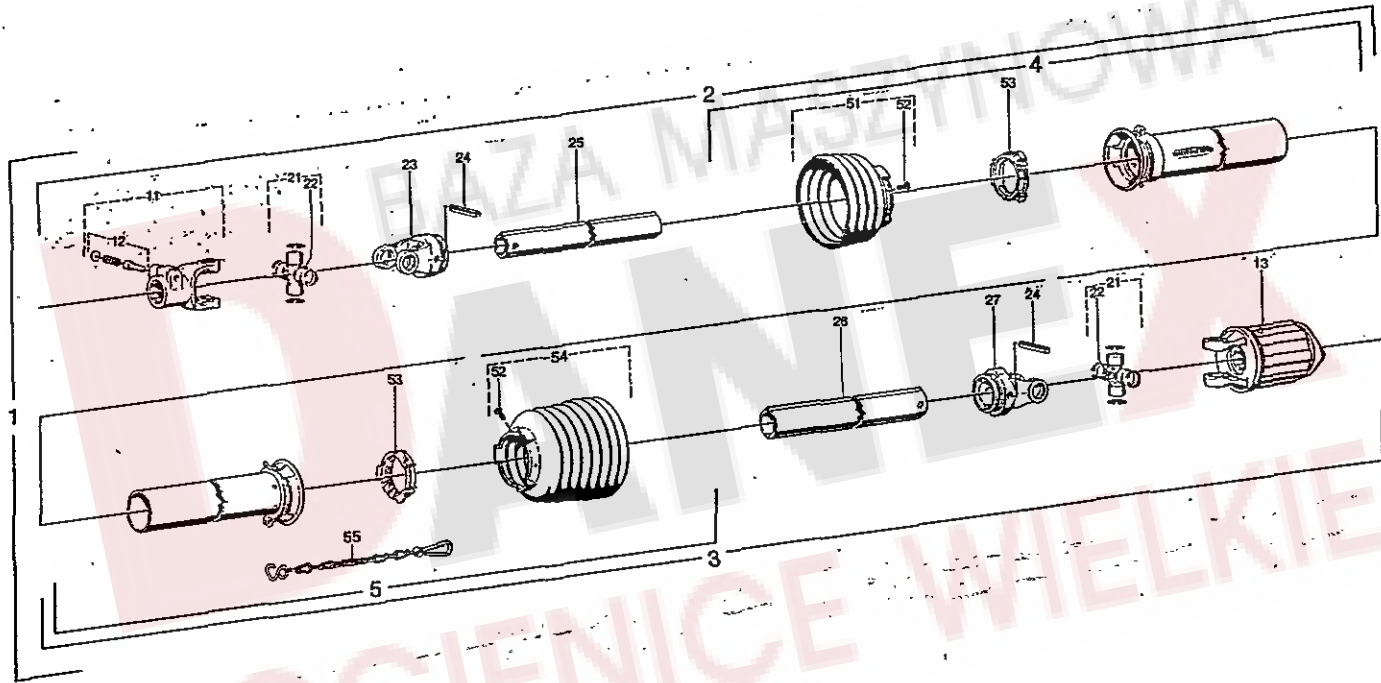

Pos.Nr. Pos.no. Rep. Pos.no.	Bezeichnung des Teiles Description of the part Désignation de la pièce Descrizione del pezzo	As of machine No. Dès le.No. de machine	* ab Masch. Nr. 5736 ** ab Masch. Nr. 5922 *** ab Masch. Nr. 276	Nr. No. No. No.	TH410 *	TH520 **	TH700 ***			
	GELENKWELLE W2200-SC 14-K33	P.T.O.-SHAFT W2200-SC14-K33	ARBRE DE TRANSMISSION W2200-SC14-K33	Fella 121 031	x	x	x			
				Walter- scheid						
				343 406	x	x	x			
2	Innere Gelenkwellenhälfte mit äußerer Schutzhälfte WH 2200-SC14	Inner p.t.o.-half with outer guard half WH2200-SC14	Demi arbre de transmission inté- rieur avec demi protecteur extérieur	330 196	x	x	x			
3	Äußere Gelenkwellenhälfte mit innerer Schutzhälfte WH2200-SC14-K33	Outer p.t.o.-half with inner guard half	Demi arbre de transmission exté- rieur avec demi protecteur intérieur	343 407	x	x	x			
4	Innere Gelenkwellenhälfte WH2200	Inner p.t.o.-half	Demi arbre de transm. intérieur	325 117	x	x	x			
5	Äußere Schutzhälfte SCH14	Outer guard half	Demi protecteur extérieur	340 209	x	x	x			
6	Innere Schutzhälfte SCH14	Inner guard half	Demi protecteur intérieur	351 541	x	x	x			
7	Äußere Gelenkwellenhälfte WH2200-K33	Outer p.t.o half	Demi arbre de transm. extérieur	342 216	x	x	x			
11	Aufsteckgabel, kompl. AG2200-1 3/8"(6)	Quick disconnect yoke, cpl.	Mâchoire à verrouillage rapide, cpl.	041 049	x	x	x			
12	Schiebestift	Quick disconnect pin, cpl.	Poussoir de verrouillage rapide, cpl.	087 245	x	x	x			
13	Druckfeder	Compression spring	Ressort de pression	087 246	x	x	x			
14	Scheibe	Washer	Rondelle	087 247	x	x	x			
15	Sternratsche, kompl. K33-R2200-1 3/8"(6) M=700-35 Nm	Star ratchet clutch cpl.	Limiteur à cames en étoile, cpl.	050 097	x	x	x			
21	Kreuzgarnitur komplett	Unit package, cpl.	Bloc croisillon complet	044 439	x	x	x			
22	Sicherungsring 24x1,5 DIN984	Snap ring	Bague de maintien	020 711	x	x	x			
23	Kegelschmiernippel BMBxl DIN71412	Conical grease nipple	Graisseur conique	020 674	x	x	x			
24	Rillengabel RG2200 0v	Grooved fork	Mâchoire à gorge	041 065	x	x	x			
25	Spannstift 10x65 DIN1481	Tension pin	Goupille	020 614	x	x	x			
26	Profilrohr 0v; L=1200	Profile tube	Tube profilé	048 203	x	x	x			
27	Profilrohr 1; L=1195	Profile tube	Tube profilé	081 873	x	x	x			
28	Rillengabel RG2200-1	Grooved fork	Mâchoire à gorge	041 068	x	x	x			
51	Schutztrichter	Guard cone	Cône protecteur	090 183	x	x	x			
52	Gleitring	Slide ring	Glissoir	087 279	x	x	x			
53	Außenschutzrohr mit Kappe L=1140	Outer protection tube with hat	Tube de protection extérieure	014 550	x	x	x			
54	Innenschutzrohr mit Kappe L=1140	Inner protection tube with hat	Tube de protection intérieure	017 577	x	x	x			
55	Schutztrichter	Guard cone	Cône protecteur	090 195	x	x	x			
56	Haltekette	Safety chain	Chainette	044 321	x	x	x			
	Ersatzteile können nur über die Fa. Walterscheid bezogen werden!	Spare parts can only be purchased directly from the Walterscheid	Les pièces peuvent seulement être achetées de chez la maison Walter- scheid.							

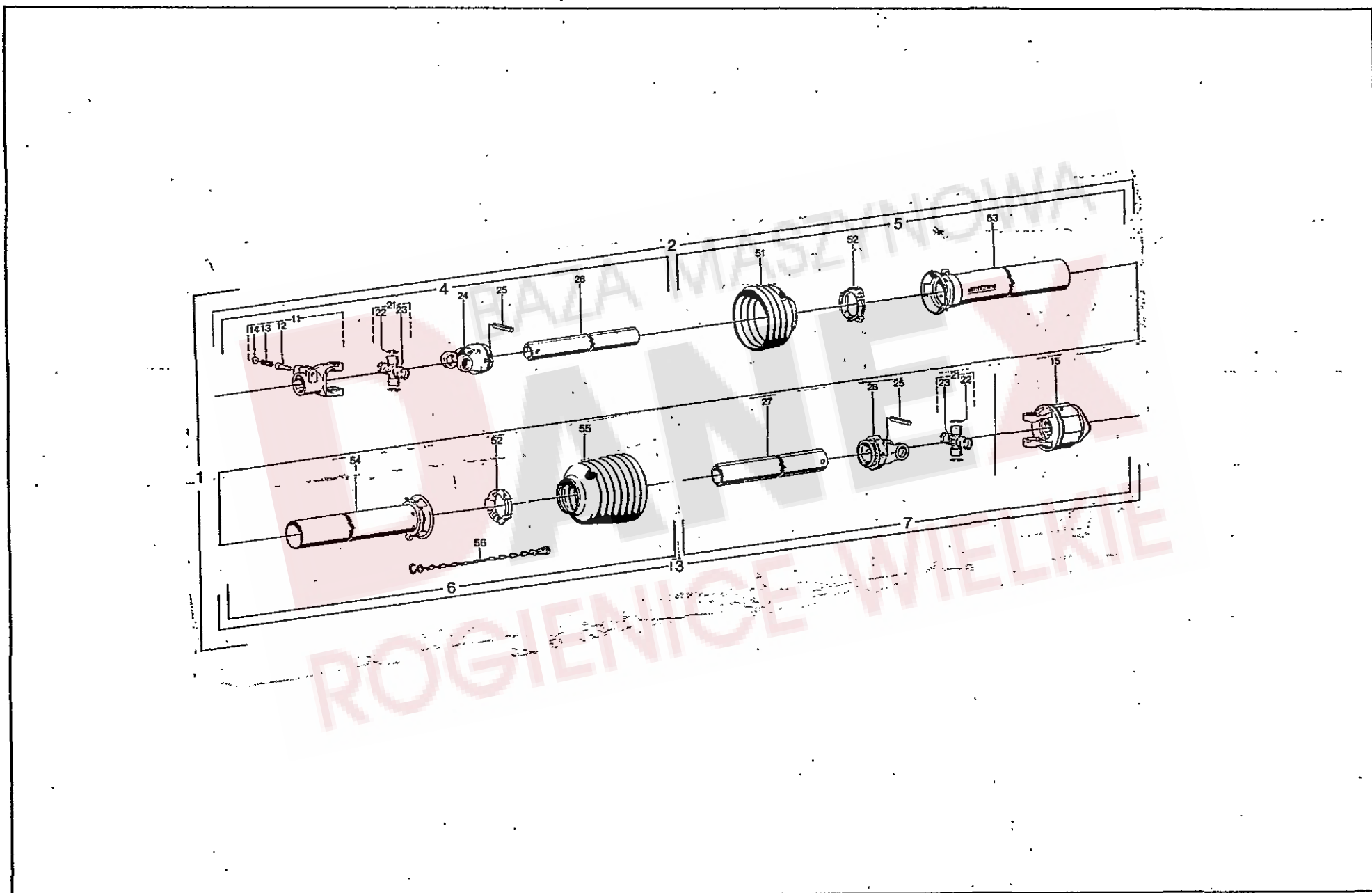

Pos.Nr. Pos.no. Rep. Pos.no.	Bezeichnung des Teiles Description of the part Désignation de la pièce Descrizions del pezzo	As of machine-No. Dès le No. de Maschine	1) ab Masch.Nr. 5736 2) ab Masch.Nr. 5922 3) ab Masch.Nr. 276.	Nr. No. No. No.	1) TH410D	2) TH520D	3) TH700D
	<b>GELENKWELLE W2200-SC14-K33</b>	<b>P.T.O.-SHAFT W2200-SC14-K33</b>	<b>ARBRE DE TRANSMISSION W2200-SC14-K33</b>	<b>Fella 121 032</b>	x	x	x
				<b>Walter- scheid 343 399</b>	x	x	x
2	Innere Gelenkwellenhälfte mit äußerer Schutzhälfte WH 2200-SC14	Inner p.t.o.-half with outer guard half WH2200-SC14	Demi arbre de transmission inté- rieur avec demi protecteur extérieur	323 320	x	x	x
3	Außere Gelenkwellenhälfte mit innerer Schutzhälfte WH2200-SC14-K33	Outer p.t.o.-half with inner guard half	Demi arbre de transmission exté- rieur avec demi protecteur intérieur	343 400	x	x	x
4	Innere Gelenkwellenhälfte WH2200	Innter p.t.o.-half	Demi arbre de transm. intérieur	085 670	x	x	x
5	Außere Schutzhälfte SCH14	Outer guard half	Demi protecteur extérieur	337 406	x	x	x
6	Innere Schutzhälfte SCH14	Inner guard half	Demi protecteur intérieur	351 540	x	x	x
7	Außere Gelenkwellenhälfte WH2200-K33	Outer p.t.o half	Demi arbre de transm. extérieur	343 401	x	x	x
11	Aufsteckgabel, kompl. AG2200-1 3/8"(6)	Quick disconnect yoke, cpl.	Mâchoire à verrouillage rapide, cpl.	041 049	x	x	x
12	Schiebestift	Quick-disconnect pin compl.	Poussoir de verrouillage rapide, cpl.	087 245	x	x	x
13	Druckfeder	Compression spring	Ressort de pression	087 246	x	x	x
14	Scheibe	Washer	Rondelle	087 247	x	x	x
15	Sternratsche, kompl. K33-R2200-1 3/8"(6) M=700±35 Nm	Star ratchet clutch cpl.	Limiteur à cames en étoile, cpl.	050 097	x	x	x
21	Kreuzgarnitur komplett	Unit package, cpl.	Bloc croisillon complet	044 439	x	x	x
22	Sicherungsring 24x1,5 DIN984	Snap ring	Bague de maintien	020 711	x	x	x
23	Kegelschmiernippel 8M8x1 DIN71412	Conical grease nipple	Graisseur conique	020 674	x	x	x
24	Rillengabel RG2200 Ov	Grooved fork	Mâchoire à gorge	041 065	x	x	x
25	Spannstift 10x65 DIN1481	Tension pin	Goupille	020 614	x	x	x
26	Profilrohr 0v; L=1200	Profile tube	Tube profilé	046 596	x	x	x
27	Profilrohr 1; L=1195	Profile tube	Tube profilé	022 484	x	x	x
28	Rillengabel RG2200-1	Grooved fork	Mâchoire à gorge	041 068	x	x	x
51	Schutztrichter	Guard cone	Cône protecteur	090 183	x	x	x
52	Gleitring	Slide ring	Glissoir	087 279	x	x	x
53	Außenschutzrohr mit Kappe L= 740	Outer protection tube with hat	Tube de protection extérieure	057 538	x	x	x
54	Innenschutzrohr mit Kappe L= 740	Inner protection tube with hat	Tube de protection intérieure	057 537	x	x	x
55	Schutztrichter	Guard cone	Cône protecteur	090 195	x	x	x
56	Haltekette	Safety chain	Chaînette	044 321	x	x	x
	Ersatzteile können nur über die Fa. Walterscheid bezogen werden!	Spare parts can only be purchased directly from the Walterscheid company!	Les pièces peuvent seulement être achetées de chez la maison Walter- scheid!				

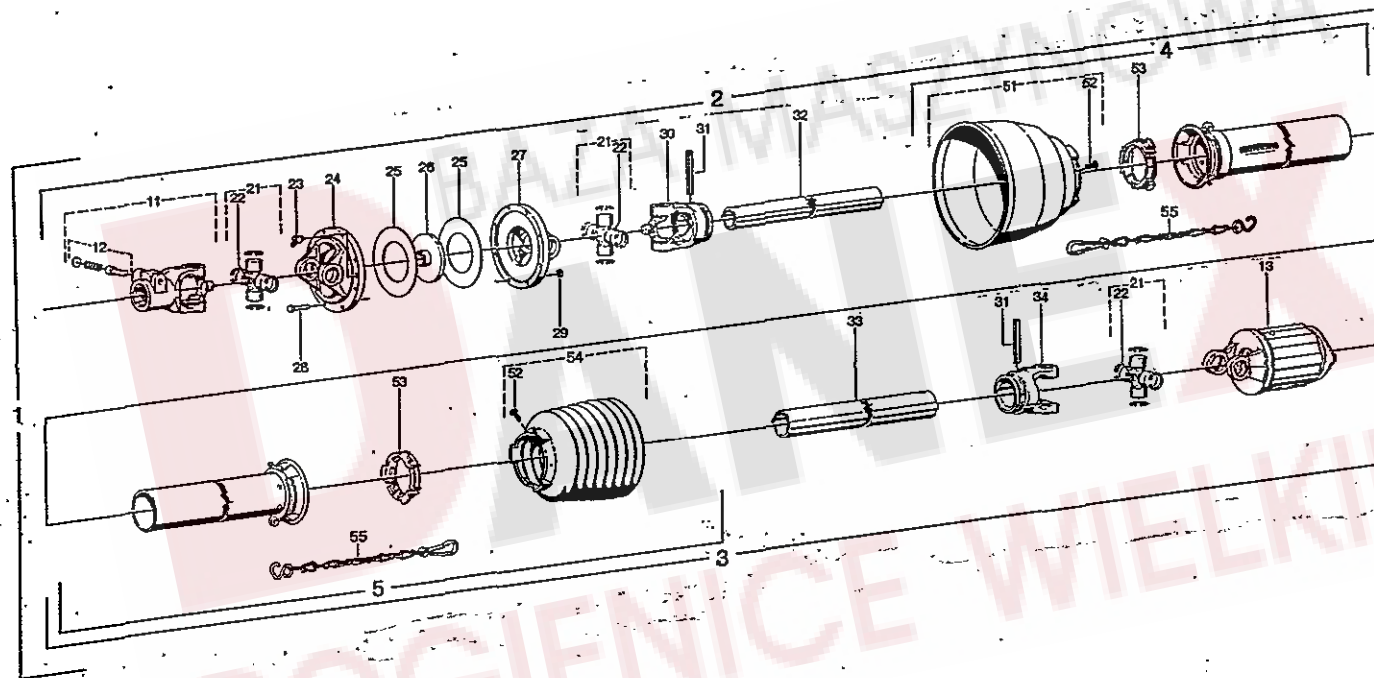

Pos.Nr. Pos.no. Rep. Pos.no.	Bezeichnung des Teiles Description of the part. Désignation de la pièce Descrizione del pezzo	As of ma chine-No. Dès le No de ma chine	* ab Masch.Nr. 5736 ** ab Masch.Nr. 5922 *** ab Masch.Nr. 276.	Nr. No. No.						
					* TH410	* TH410D	** TH520	** TH520D	*** TH700	*** TH700D
	<b>SONDERZUBEHÖR</b>	<b>SPECIAL EQUIPMENT</b>	<b>EQUIPEMENT SPECIAL</b>	<b>Fella</b>						
	<b>WEITWINKEL-GELENKWELLE</b>	<b>WIDE-ANGLE P.T.O. SHAFT</b>	<b>ARBRE A CARDAN GRAND ANGLE</b>	<b>121 038G</b>	x	x	x	x	x	x
	<b>WW 2200-SC15-1410-K33B</b>	<b>WW 220-SC15-1410-K33B</b>		<b>Walter-</b>						
				<b>scheid</b>						
1	WW-Gelenkwelle WW 2200-SC15-1410-K33B	Wide-angle p.t.o.-shaft	Arbre à cardan grand-angle	364 906	x	x	x	x	x	x
2	Innere Weitwinkel-Gleichlaufgelenkwellenhälfte mit äußerer Schutzhälfte WW2200-SC15-1335	Inner synchronizing p.t.o.-shaft half with outer guard half	Demi arbre à cardan grand-angle de synchronisation avec demi-protecteur extérieur	336 853	x	x	x	x	x	x
3	Äußere Gelenkwellenhälfte mit innerer Schutzhälfte WH2200-SC15-1260-K33B	Outer p.t.o.-half with inner guard half	Demi arbre de transm. extérieur avec demi-protecteur intérieur	364 907	x	x	x	x	x	x
4	Äußere Schutzhälfte SCH15; L=1165mm	Outer guard half	Demi-protecteur extérieur	379 519	x	x	x	x	x	x
5	Innere Schutzhälfte SCH15; L=1160mm	Inner guard half	Demi-protecteur intérieur	160 778	x	x	x	x	x	x
11	Aufsteckgabel, komplett WAG2200-1 3/8"(6)	Quick disconnect yoke, cpl.	Mâchoire à verrouillage rapide, cpl.	041 059	x	x	x	x	x	x
12	Schiebestift, kompl.	Sliding pin, cpl.	Glissoir, compl.	339 107	x	x	x	x	x	x
13	Sternratsche, kompl. K33 B-2200-1 3/8"(6) M=700 Nm	Star ratched clutch, compl.	Limiteur à cames en étoile, cpl.	363 138	x	x	x	x	x	x
21	Kreuzgarnitur, kompl.	Unit package, cpl.	Bloc croisillon compl.	044 439	x	x	x	x	x	x
22	Kegelschmiernippel M8x1	Conical grease nipple	Graisseur conique	084 099	x	x	x	x	x	x
23	Kegelschmiernippel BM8x1 DIN71412	Conical grease nipple	Graisseur conique	020 674	x	x	x	x	x	x
24	Flanschgabel FG2200-Ø130	Flange fork	Mâchoire à bride	041 195	x	x	x	x	x	x
25	Scheibe	Washer	Rondelle	042 861	x	x	x	x	x	x
26	Führungsnahe	Guiding hub	Moyeu de guidage	044 284	x	x	x	x	x	x
27	Flanschgabel FG2200-Ø 130	Flange fork	Mâchoire à bride	041 196	x	x	x	x	x	x
28	6kt.-Schraube M6x30DIN933	Hexagonal bolt	Vis à 6 pans	020 510	x	x	x	x	x	x
29	6kt.-Mutter M6 DIN934	Hexagonal nut	Ecrou à 6 pans	020 545	x	x	x	x	x	x
30	Rillengabel WRG2200-0V	Grooved fork	Mâchoire à gorge	041 066	x	x	x	x	x	x
31	Spannstift 10x65 DIN1481	Tension pin	Goupille	020 614	x	x	x	x	x	x
32	Profilrohr, beschichtet OvGA; L=1220mm	Profile tube	Tube profilé	329 824	x	x	x	x	x	x
33	Profilrohr 1G; L=1220mm	Profile tube	Tube profilé	017 581	x	x	x	x	x	x
34	Rillengabel RG 2200-1	Grooved fork	Mâchoire à gorge	041 068	x	x	x	x	x	x
51	Schutztrichter mit Schraube	Guard cone with screw	Cône protecteur avec vis	365 246	x	x	x	x	x	x
52	Schraube 4x10	Screw	Vis	365 305	x	x	x	x	x	x
53	Gleitring	Slide pin	Glissoire	087 279	x	x	x	x	x	x
54	Schutztrichter mit Schraube	Guard cone with screw	Cône protecteur avec vis	365 348	x	x	x	x	x	x
55	Haltekette	Safety chain	Chaînette	044 321	x	x	x	x	x	x
	Ersatzteile können nur über die Fa. Walterscheid bezogen werden!	These parts can only be purchased directly from the Walterscheid company!	Cettes pièces peuvent seulement être achetées directement de chez la maison Walterscheid!							

# Ersatzteilliste

## NUMMERNVERZEICHNIS

### INDEX OF NUMBERS

## LIST NUMERIQUE

### INDICE PER NUMERI

Bestell-Nr. Part no No de commande No d'ordinazione	Tafel Table Tableau Tavola	Pos.-Nr. Pos.-no No de pos. Pos. No	Bestell-Nr. Part no No de commande No d'ordinazione	Tafel Table Tableau Tavola	Pos.-Nr. Pos.-no No de pos. Pos. No	Bestell-Nr. Part no No de commande No d'ordinazione	Tafel Table Tableau Tavola	Pos.-Nr. Pos.-no No de pos. Pos. No	Bestell-Nr. Part no No de commande No d'ordinazione	Tafel Table Tableau Tavola	Pos.-Nr. Pos.-no No de pos. Pos. No
018 221	5.27		109 205	9.04		121 090	10.20		461 106	1.11	
105 186	3.16	4.30	109 239	2.33		121 091	10.21		463 078	1.50	
105 327	9.06		109 363	1.40	7.21	121 092	10.22		464 006	8.02	4.22
105 463	1.42	2.28	109 455	1.10		121 096	5.26		477 656	1.29	
105 524	1.33	2.09	109 470	6.07		121 170	4.32		478 324	6.25	
106 857	5.18	6.24	109 471	2.32		121 327	4.26		478 786	6.26	7.33
107 047	1.18		110 860	1.55		121 389	8.09		482 084	4.38	
107 104	1.26		111 216	1.15		121 594	7A.19		486 050	1.05	
107 150	2.03		111 804	8.21		121 608	4.42		486 061	1.20	
107 367	1.04	9.12	111 895	2.37	6.09	121 609	4.40		486 071	1.01	
107 383	1.25	2.08	115 527	7A.22	8.17	121 610	4.41		486 103	9.07	
107 385	1.03	9.09	115 916	6.22	8.18	121 617	8.15		486 107	9.11	
107 425	7.01		115 972	7.12	8.23	121 834	2.30	3.33	486 113	9.02	
107 435	8.10		115 980	7A.20	9.17	121 977	10.12		486 178	9.10	
107 440	7.16	7A.10	115 983	1.07		124 053	2.36	6.28	486 181	1.11	
107 441	2.24	3.24	115 991	6.13	7.26	124 156	4.35		486 964	8.12	
107 443	4.37		115 997	7.11	10.11	124 268	1.37	7.24	486 976	8.11	
107 449	7.15	7A.21	116 049	9.16		124 269	1.53		486 987	2.12	
107 451	1.54		116 051	1.59	2.25	124 279	10.16		487 000	1.56	2.20
107 452	5.09	5.28	116 224	8.22	8.03	124 287	6.10		487 181	10.06	
	7A.16		116 477	1.38		124 289	1.22		487 182	10.05	
107 453	5.04	6.27	116 484	1.36		124 290	6.29	7.28	487 186	10.00	
107 465	1.57	2.15	116 486	1.35	7.25	124 292	9.14		487 187	8.20	
	3.11	6.18	116 513	6.12	7.13	124 295	6.21		487 188	8.16	
107 467	4.36		116 530	8.04	10.02	124 330	4.03		487 189	10.08	
107 470	8.19		116 536	6.02		124 331	2.39	3.20	487 192	10.09	
107 478	1.41	2.27	116 614	1.45	10.10	124 395	3.31	3.25	487 194	10.00	
107 727	9.15		116 622	1.08		124 436	4.07		487 203	1.23	2.06
107 738	1.58	2.17	116 627	5.23	7.29	124 502	1.09	3.03	487 213	7.05	3.04
107 740	6.04	3.14	116 628	5.05	7A.04	124 504	2.38	3.26	487 237	3.10	
107 811	5.15		116 629	4.29	8.05	124 710	4.17		487 271	7.35	7A.07
108 292	3.19	4.39	116 630	4.29		124 757	1.19	1.24	487 326	5.07	
108 294	3.12	7A.25	116 699	1.39	5.30	124 758	1.02	2.05	487 337	5.03	
108 384	3.27		116 746	1.14	7.22	124 778	3.32	4.02	487 337	5.03	
108 415	7.14		116 749	2.14		124 939	1.48		487 345	5.12	
108 441	1.06		117 244	6.23		126 159	2.31	3.21	487 348	5.08	
108 531	1.47	4.34	117 418	7A.12		126 375	4.06		487 353	5.20	
	8.06	10.04	117 848	4.16		126 429	4.04		487 354	5.21	
	9.08	10.13	118 070	5.24	7.30	223 679	1.51		487 363	5.14	
108 570	5.11		118 440	1.32	2.07	226 230	5.29		487 364	5.16	
108 587	5.06	6.08	118 973	2.13	3.18	238 009	3.28		487 369	5.02	
108 589	5.06	8.07	120 034	5.22		240 309	4.21	8.24	487 376	5.10	
108 606	9.03		120 054	5.17		354 560	5.13		487 380	4.27	
108 611	1.46		120 778	2.10	3.09	355 939	7.08	7A.06	487 401	2.52	
108 745	1.16	2.18	120 595	4.05		406 592	7A.13		487 402	4.28	
109 162	10.07		121 066	4.12		455 777	1.21		487 403	1.34	
109 179	7.07	7A.05							487 404	1.30	



# Ersatzteilliste

## NUMMERNVERZEICHNIS

### INDEX OF NUMBERS

## LIST NUMERIQUE

### INDICE PER NUMERI

Bestell-Nr.	Tafel	Pos.-Nr.	Bestell-Nr.	Tafel	Pos.-Nr.	Bestell-Nr.	Tafel	Pos.-Nr.	Bestell-Nr.	Tafel	Pos.-Nr.		
Part no	Table	Pos.-no	Part no	Table	Pos.-no	Part no	Table	Pos.-no	Part no	Table	Pos.-no		
No de commande	Tableau	No de pos.	No de commande	Tableau	No de pos.	No de commande	Tableau	No de pos.	No de commande	Tableau	No de pos.		
No d'ordinazione	Tavola	Pos. No	No d'ordinazione	Tavola	Pos. No	No d'ordinazione	Tavola	Pos. No	No d'ordinazione	Tavola	Pos. No		
487 408	4.43		487 661	9.20		488 100	4.15		044 439	11.21	12.21 13.21		
487 413	3.01		487 662	10.03	10.18	488 169	8.01		046 596	12.26			
487 414	3.23		487 663	10.01	10.15	488 170	8.13		048 203	11.26			
487 429	6.20		487 656	7.32		488 174	8.01		050 097	11.15	12.15		
487 432	5.01		487 676	10.17		488 175	8.13		057 537	12.54			
487 436	5.01		487 677	10.00		488 177	8.01		057 538	12.53			
487 442	9.01		487 695	2.34	6.06	488 178	8.13		081 873	11.27			
487 446	7.23		487 760	1.31	2.16 3.13	488 220	3.02		084 099	13.22			
487 457	7.18	7A.08	487 818	1.13		488 221	1.27	2.26	085 670	12.04			
487 459	7.06		487 821	4.09		488 252	3.02		087 245	11.12	12.12		
487 460	7.20		487 859	6.01		488 254	2.29	3.08	087 246	11.13	12.13		
487 461	4.08		487 863	5.01		488 262	2.02		087 247	11.14	12.14		
487 464	4.11		487 866	6.03		488 263	3.02		087 279	11.52	12.52 13.53		
487 467	4.13		487 872	4.14		488 274	7A.11		090 183	11.51	12.51		
487 473	1.12		487 873	4.24		488 319	10.14		090 195	11.55	12.55		
487 479	4.10		487 922	4.33		488 320	10.00		121 031	11.00			
487 481	4.01		487 927	2.11		488 331	4.18		121 032	12.00			
487 482	6.16		487 928	2.22		488 332	4.25		121 038	13.00			
487 495	6.01		487 955	1.13		488 456	4.20		160 778	13.05			
487 496	5.25		487 970	1.43		490 357	5.19	7.37	323 320	12.02			
487 514	6.17		487 971	1.44		491 076	7.03	7A.15	325 117	11.04			
487 520	1.13		487 975	1.49		<b>WALTERSCHEID</b> Getriebeweile PTO drive shaft Transmission			329 824	13.32			
487 525	3.01		487 976	2.19					330 196	11.02			
487 526	3.23		487 979	2.01					336 853	13.02			
487 534	1.17		487 980	2.01					337 406	12.05			
487 535	1.17		487 986	2.23					339 107	13.12			
487 536	1.30		487 987	1.34				014 550	11.53		340 209	11.05	
487 537	1.34		487 988	1.30				017 577	11.54		342 216	11.07	
487 547	1.49		487 990	2.23				017 581	13.33		343 399	12.00	
487 548	1.26	2.04 3.06	488 009	3.01				020 510	13.28		343 400	12.03	
487 553	1.56	3.30	488 010	3.23				020 545	13.29		343 401	12.07	
487 587	6.15		488 011	3.01		020 614	11.25	12.25 13.31	343 406	11.00			
487 597	8.08		488 012	3.23		020 674	11.23	12.23 13.23	343 407	11.03			
487 598	8.11		488 020	8.08		020 711	11.22	12.22	351 540	12.06			
487 600	8.08		488 024	8.14		022 484	12.27		351 541	11.06			
487 631	7.31		488 029	8.11		041 049	11.11	12.11	363 138	13.13			
487 632	6.11		488 036	7A.02		041 059	13.11		364 906	13.01			
487 637	9.00		488 042	6.15		041 065	11.24	12.24	364 907	13.03			
487 639	9.05		488 051	7A.01		041 066	13.30		365 246	13.51			
487 641	9.13		488 056	7A.17		041 068	11.28	12.28 13.34	365 305	13.52			
487 643	7.09		488 059	10.00		041 195	13.24		365 348	13.54			
487 645	7.27		488 072	4.33		041 196	13.27		379 519	13.04			
487 646	7.17	7A.09	488 073	3.29		042 861	13.25						
487 647	7.04		488 087	4.43		044 284	13.26						
487 649	3.22		488 099	4.31		044 321	11.56	12.56 13.55					